



# PRODUCTION SPECIFICATION OF LCD MODULE

**MODULE NO. DW04002YB30B-C**

---

<b>Customer Name:</b>			
<b>Customer Part Number:</b>			
<b>Approved By:</b>		<b>Date:</b>	

<b>Prepared By</b>	<b>Checked By</b>	<b>Approved By</b>



## Table of Contents

Revision History.....	3
1 General Specifications.....	4
2 Pin Assignment.....	5
3 Absolute Maximum Ratings.....	6
4 Electrical Characteristics.....	6
5 INTERFACE TIMING.....	9
5.1 System Bus Read/Write Characteristics.....	9
5.2 Power ON/OFF Timing.....	10
6 Optical Characteristics.....	11
7 Environmental / Reliability Test.....	15
8 Mechanical Drawing.....	16
9 Precautions For Use of LCD Modules.....	17



## Revision History

Rev	Issued Date	Description	Page	Editor
1.0	Mar 22.2018	First release	All	



## 1 General Specifications

	Feature	Specifications
<b>Display Spec.</b>	LCD type	4.0 inch
	Resolution (H*V)	720(RGB) × 720
	Technology Type	a-Si TFT
	Pixel Configuration	R.G.B. Vertical Stripe
	Display Mode	Normally Black
	Viewing Direction	ALL
	Gray Scale Inversion Direction	-
<b>Mechanical Characteristics</b>	OutlineDimensions (W x H x T) (mm)	84.0*84.0*2.6
	Active Area(mm)	71.93*71.93
	CTP View Area(mm)	72.53*72.53
	With /Without Touch screen	With CTP
	Connector Type	0.5PITCH
	Backlight Type	LED
	Weight (g)	TBD
<b>Electrical Characteristics</b>	Display Interface	MIPI
	Touch Interface	I2C
	Number of color	16.7M
	Display Driver IC	YY1821
	Touch Driver IC	FT6336U

Note 1: Viewing direction for best image quality is different from TFT definition. There is a 180 degree shift.



## 2 Pin Assignment

NO.	PIN NAME	Description
1	LED A	LED ANODE
2	LED K1	LED CATHODE
3	LED K2	LED CATHODE
4	VCI	Power supply
5	IOVCC	Power supply
6	RESET	Reset Signal ,Active Low
7	TE	Tearing effect
8	PWM	LCD backlight control PWM
9	GND	Ground
10	D0P	MIPI DSI differential data pair (Data lane 0)
11	D0N	MIPI DSI differential data pair (Data lane 0)
12	GND	Ground
13	D1P	MIPI DSI differential data pair (Data lane 1)
14	D1N	MIPI DSI differential data pair (Data lane 1)
15	GND	Ground
16	CLKP	MIPI DSI differential clock pair
17	CLKN	MIPI DSI differential clock pair
18	GND	Ground
19	D2P	MIPI DSI differential data pair (Data lane 2)
20	D2N	MIPI DSI differential data pair (Data lane 2)
21	GND	Ground
22	D3P	MIPI DSI differential data pair (Data lane 3)
23	D3N	MIPI DSI differential data pair (Data lane 3)
24	GND	Ground
25	TP_INT	Touch Interrupt
26	TP_SDA	Touch IIC Data signal
27	TP_SCL	Touch IIC Clock signal
28	TP_RESET	Touch Reset Signal
29	TP_VCI	Touch Power supply
30	GND	Ground



### 3 Absolute Maximum Ratings

GND=0V, Ta= 25°C

Item	Symbol	Value	Unit
Power supply voltage for logic	V <sub>DD</sub>	0.3~3.6	V
Input voltage	V <sub>in</sub>	V <sub>DD</sub> +0.3	V
Operating temperature	T <sub>opr</sub>	-20 to 70	°C
Storage temperature	T <sub>stg</sub>	-30 to 80	°C

**Note:** Note1: Absolute maximum rating is the limit value beyond which the IC maybe broken.

They do not assure operations.

Note2: Background color changes slightly depending on ambient temperature. This Phenomenon is reversible.

Ta ≤ 70°C: 75%RH max

Ta > 70°C: absolute humidity must be lower than the humidity of 75%RH at 70°C

Note3: Ta at -30°C will be <48hrs, at 80 °C will be <120hrs

### 4 Electrical Characteristics

#### 4.1 Driving TFT LCD Panel

Item	Symbol	Min.	Max.	Unit	Note
LC Operating Voltage	V <sub>OP</sub>	--	4.5	V	*1,*2
Operating Temperature	T <sub>OP</sub>	-20	70	°C	
Storage Temperature	T <sub>ST</sub>	-30	80	°C	
Operating Ambient Humidity	H <sub>OP</sub>	10	*4	RH	*3
Storage Humidity	H <sub>ST</sub>	10	*4	RH	*3

Note:

\*1. At 25±5°C

\*2. Due to the characteristics of LC Material, the Liquid Crystal driving voltage varies with environmental temperature.

\*3. Non-condensation.

\*4. Temp. ≤ 60°C, 90%RH Max.

Temp. > 60°C, Absolute humidity shall be less than 90%RH.



## 4.2 Driving Backlight

Ta=25°C

Item	Symbol	Min	Typ	Max	Unit	Remark
Forward Current	$I_F$	--	40	50	mA	
Forward Voltage	$V_F$	-	12.8	-	V	
Connection mode		--	4S2P	--		
LED number	/		8		pcs	

Note1: Optical performance should be evaluated at Ta=25°C only .If LED is driven by high current, high ambient temperature & humidity condition. The life time of LED will be reduced. Operating life means brightness goes down to 50% initial brightness. Typical operating life time is estimated data.

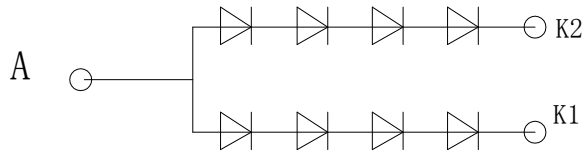

BLU CIRCUIT DIAGRAM



### 4.3 Block Diagram

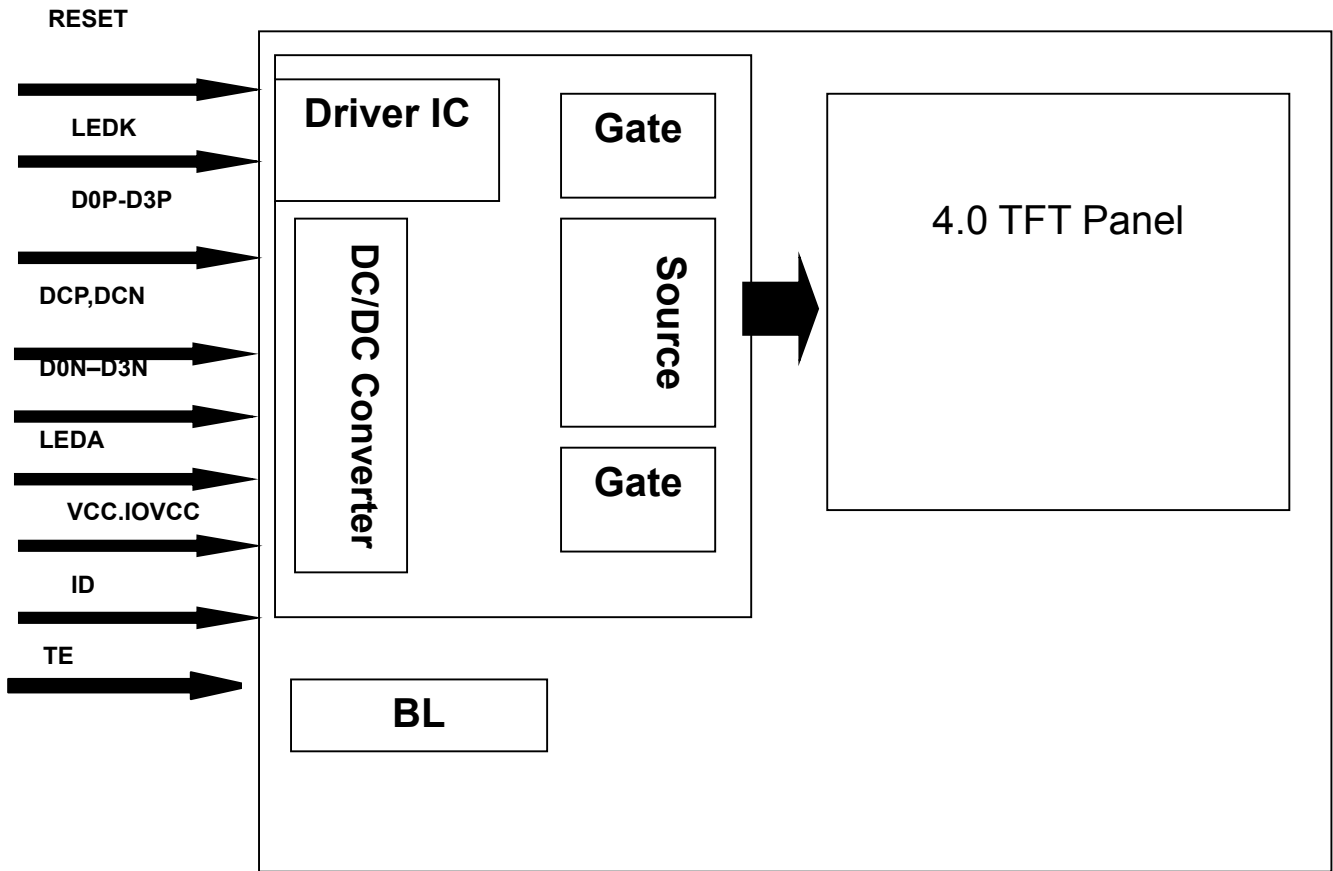





## 5 INTERFACE TIMING

### 5.1 System Bus Read/Write Characteristics.

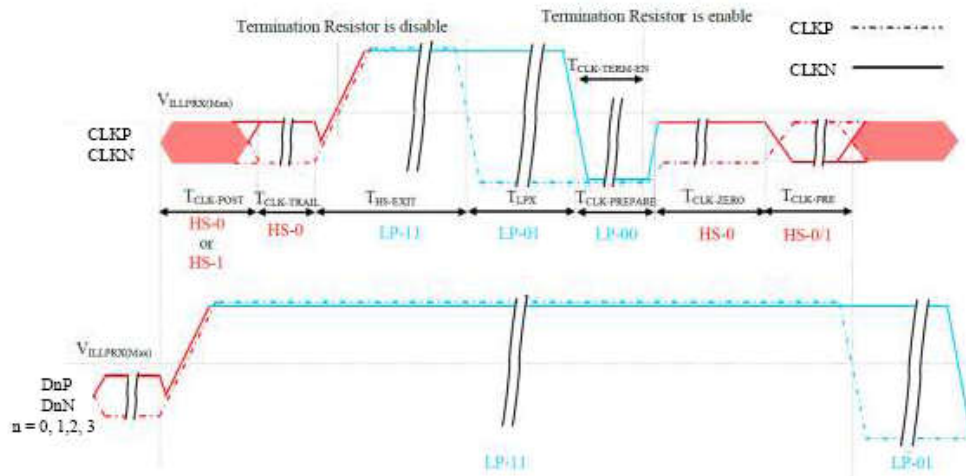

Figure 123: Clock Lanes - High Speed Mode to/from Low Power Mode Timings

Table 46: Clock Lanes - High Speed Mode to/from Low Power Mode Timings

Signal	Symbol	Description	Min	Max	Unit
CLKP/N	$T_{CLK-POST}$	Time that the MCU shall continue sending HS clock after the last associated Data Lanes has transitioned to LP mode	$60+52xUI$	-	ns
CLKP/N	$T_{CLK-TRAIL}$	Time to drive HS differential state after last payload clock bit of a HS transmission burst	60	-	ns
CLKP/N	$T_{HS-EXT}$	Time to drive LP-11 after HS burst	100	-	ns
CLKP/N	$T_{CLK-PREPARE}$	Time to drive LP-00 to prepare for HS transmission	38	95	ns
CLKP/N	$T_{CLK-TERM-EN}$	Time-out at Clock Lane to enable HS termination	-	38	ns
CLKP/N	$T_{CLK-PREPARE} + T_{CLK-ZERO}$	Minimum lead HS-0 drive period before starting Clock	300	-	ns
CLKP/N	$T_{CLK-PRE}$	Time that the HS clock shall be driven prior to any associated Data Lane beginning the transition from LP to HS mode	$8xUI$	-	ns



## 5.2 Power ON/OFF Timing

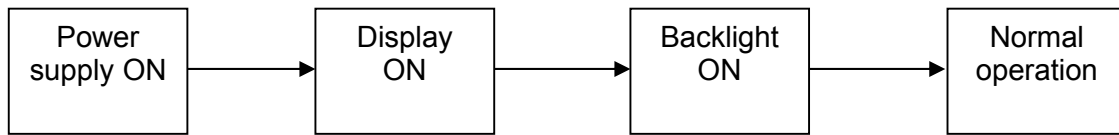
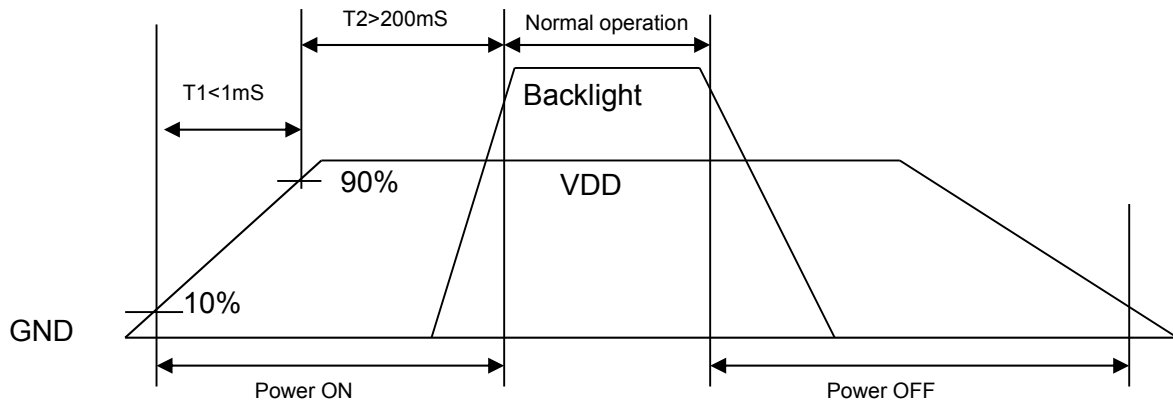

Power ON sequence

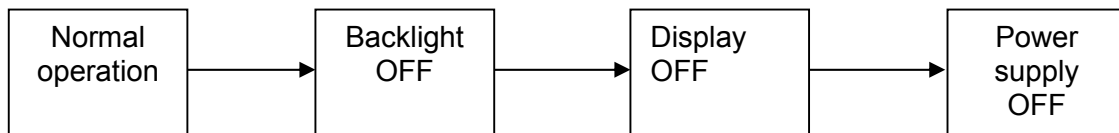

Power OFF sequence



## 6 Optical Characteristics

Ta=25°C

Item	Symbol	Condition	Min	Typ	Max	Unit	Remark
View Angles	θT	CR ≥ 10	-	80	-	Degree	Note 2
	θB		-	80	-		
	θL		-	80	-		
	θR		-	80	-		
Contrast Ratio	CR	θ=0°	700	900	-	-	Note1 Note3
Response Time	T <sub>ON</sub>	25°C	-	30	40	ms	Note1
	T <sub>OFF</sub>		Note4				
Uniformity	U	-	70	80	-	%	Note1 Note6
NTSC	-	-	-	70	-	%	Note 5
Luminance	L		250	300	-	cd/m <sup>2</sup>	Note1 Note7

Test Conditions:

1.  $V_F=19.2V$ ,  $I_F=40mA$ , the ambient temperature is 25°C.
2. The test systems refer to Note 1 and Note 2.



**Note 1: Definition of optical measurement system.**

The optical characteristics should be measured in dark room. After 5 minutes operation, the optical properties are measured at the center point of the LCD screen. All input terminals LCD panel must be ground when measuring the center area of the panel.

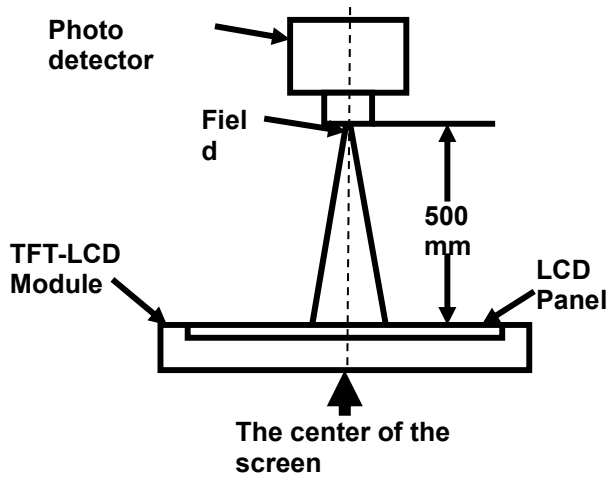

Item	Photo detector	Field
Contrast Ratio	SR-3A	1°
Luminance		
Chromaticity		
Lum Uniformity	BM-7A	2°
Response Time		

**Note 2: Definition of viewing angle range and measurement system.**

viewing angle is measured at the center point of the LCD by CONOSCOPE(ergo-80).

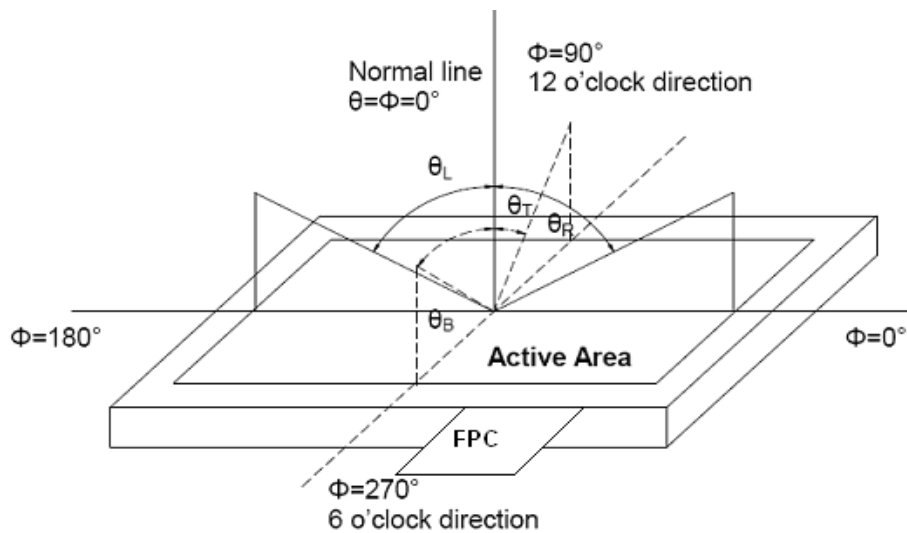

Fig. 1 Definition of viewing angle



### Note 3: Definition of contrast ratio

$$\text{Contrast ratio (CR)} = \frac{\text{Luminance measured when LCD is on the "White" state}}{\text{Luminance measured when LCD is on the "Black" state}}$$

“White state “:The state is that the LCD should be driven by  $V_{\text{white}}$ .

“Black state”: The state is that the LCD should be driven by  $V_{\text{black}}$ .

$V_{\text{white}}$ : To be determined     $V_{\text{black}}$ : To be determined.

### Note 4: Definition of Response time

The response time is defined as the LCD optical switching time interval between “White” state and “Black” state. Rise time ( $T_{\text{ON}}$ ) is the time between photo detector output intensity changed from 90% to 10%. And fall time ( $T_{\text{OFF}}$ ) is the time between photo detector output intensity changed from 10% to 90%.

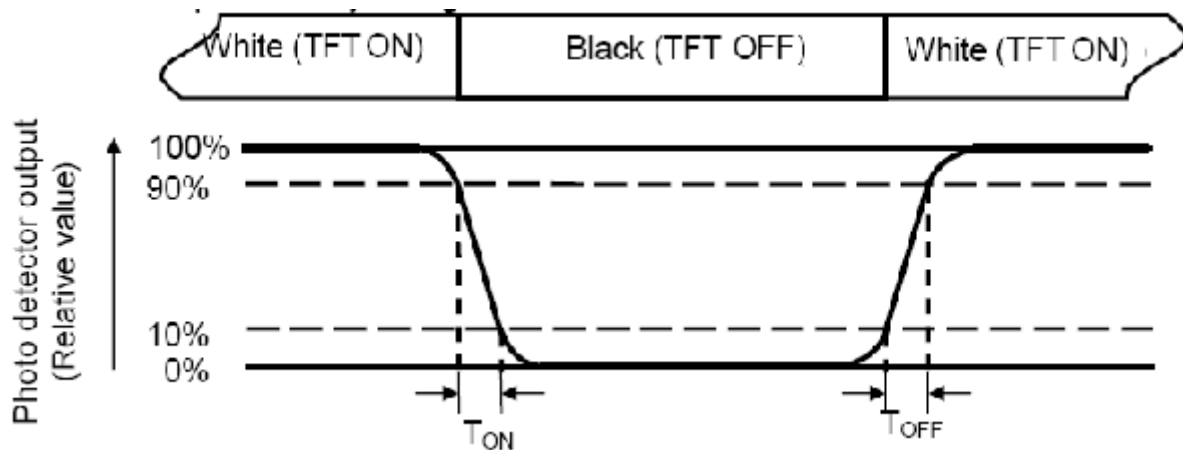

### Note 5: Definition of color chromaticity (CIE1931)

Color coordinates measured at center point of LCD.



### Note 6: Definition of Luminance Uniformity

Active area is divided into 9 measuring areas (Refer Fig. 2). Every measuring point is placed at the center of each measuring area.

Luminance Uniformity (U) =  $L_{min} / L_{max}$

L-----Active area length W----- Active area width

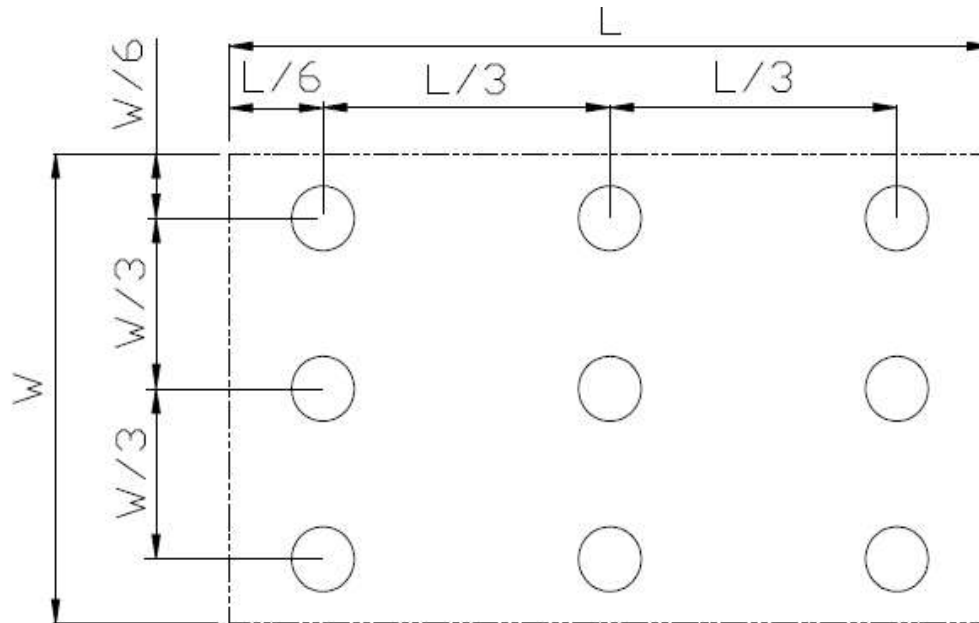

Fig. 2 Definition of uniformity

$L_{max}$ : The measured maximum luminance of all measurement position.

$L_{min}$ : The measured minimum luminance of all measurement position.

### Note 7: Definition of Luminance:

Measure the luminance of white state at center point.



## 7 Environmental / Reliability Test

Item	Condition	Time (hrs)	Assessment
High temp. Storage	80°C	120	No abnormalities in functions and appearance
High temp. Operating	70°C	120	
Low temp. Storage	-30°C	120	
Low temp. Operating	-20°C	120	
Humidity	40°C/ 90%RH	120	
Thermal Shock(Non-operation)	-20°C ← 25°C →70°C (0.5 hour ← 5 min → 0.5 hour)	10cycles	



# 8 Mechanical Drawing

1	2	3	4	5	6	7	8
<b>Kingtech Group Co., Ltd.</b>		DESIGN: (设计)	CHECKED: (检查)	APPROVED: (批准)	SPECIFICATION	规格	
Date: (日期) 2018-03-22		Page: (页数) 1/1		图纸视角:	CUSTOMER'S CODE: (客户型号)	DWC04002YB30B-C	EDITION: (版本号) 01
				KT'S CODE: (料号)			

**4. 0TFT**  
**720\*720**  
**ALL**

元件的厚度为1mm, 不含FPC

PIN SYMBOL

1	LEDA
2	LEDK1
3	LEDK2
4	VC1
5	IOWCC
6	RESET
7	TE
8	PWM
9	GND
10	DOP
11	DON
12	GND
13	D1P
14	D1N
15	GND
16	CLKP
17	CLKN
18	GND
19	D2P
20	D2N
21	GND
22	D3P
23	D3N
24	GND
25	TP_INT
26	TP_SDA
27	TP_SCL
28	TP_RESET
29	TP_VCI
30	GND

1. Unit:mm  
 2. ΔModification rev.number.  
 3. All radii without dimension R0.3mm.  
 4. All draft angles to be 1.5°  
 5. Unspecified Tolerances is: ±0.20mm.  
 6. LCD Driver IC: WY1821  
 7. LCD Driver Voltage : 2.8±0.3V  
 8. Color :White  
 9. Operating Temperature : -20° --- +70° C  
 10. Storage Temperature : -30° --- +80° C  
 11. Requirements on Environmental Protection: ROHS

Customer Name: 客户名称  
 Approval Date: 承认日期  
 Approved By: 承认

Please Confirm This Drawing On/Before 请 签 回 此 图

标示	日期	更改内容	签署





## 9 Precautions For Use of LCD Modules

### 9.1 Handling Precautions

9.1.1.1 The display panel is made of glass. Do not subject it to a mechanical shock by dropping it from a high place, etc.

9.1.1.2 If the display panel is damaged and the liquid crystal substance inside it leaks out, be sure not to get any in your mouth, if the substance comes into contact with your skin or clothes, promptly wash it off using soap and water.

9.1.1.3 Do not apply excessive force to the display surface or the adjoining areas since this may cause the color tone to vary.

9.1.1.4 The polarizer covering the display surface of the LCD module is soft and easily scratched. Handle this polarizer carefully.

9.1.1.5 If the display surface is contaminated, breathe on the surface and gently wipe it with a soft dry cloth. If still not completely clear, moisten cloth with one of the following solvents:

- Isopropyl alcohol
- Ethyl alcohol

Solvents other than those mentioned above may damage the polarizer. Especially, do not use the following:

- Water
- Ketone
- Aromatic solvents

9.1.1.6 Do not attempt to disassemble the LCD Module.

9.1.1.7 If the logic circuit power is off, do not apply the input signals.

9.1.1.8 To prevent destruction of the elements by static electricity, be careful to maintain an optimum work environment.

9.1.1.9 Be sure to ground the body when handling the LCD Modules.

9.1.1.10 Tools required for assembly, such as soldering irons, must be properly ground.

9.1.1.11 To reduce the amount of static electricity generated, do not conduct assembly and other work under dry conditions.

9.1.1.12 The LCD Module is coated with a film to protect the display surface. Be care when peeling off this protective film since static electricity may be generated.

9.1.1.13 Storage precautions

9.1.1.14 When storing the LCD modules, avoid exposure to direct sunlight or to the light of fluorescent lamps.

9.1.1.15 The LCD modules should be stored under the storage temperature range. If the LCD modules will be stored for a long time, the recommend condition is:

9.1.1.16 Temperature : 0°C ~ 40°C      Relatively humidity: ≤80%

9.1.1.17 The LCD modules should be stored in the room without acid, alkali and harmful gas.

### 9.2 Transportation Precautions

The LCD modules should be no falling and violent shocking during transportation, and also should avoid excessive press, water, damp and sunshine.