



# SPECIFICATION:

**Product Model: PV012101LZR20B**

DESIGNED	CHECKED	Approved

## Approval by Customer:

Ok

NG, Problem survey

Approved By \_\_\_\_\_





## Table of Contents

List	Description	Page No.
	Cover	1
	Revision Record	2
	Table of Contents	3
1	Scope	4
2	General Information	4
3	External Dimensions	5
4	Interface Description	6
5	Absolute Maximum Ratings	8
6	DC Characteristics	8
7	Timing Characteristics	9
8	Backlight Characteristics	14
9	Optical Characteristics	15
10	Reliability Test Conditions and Methods	17
11	Inspection Standard	18
12	Handling Precautions	22
13	Precaution for Use	23
14	Packing Method	24



## 1. Scope

This specification defines general provisions as well as inspection standards for TFT module supplied by Kingtech Group Co.,Ltd.

If the event of unforeseen problem or unspecified items may occur, naturally shall negotiate and agree to solution

## 2. General Information

ITEM	STANDARD VALUES	UNITS
LCD type	12.1" TFT	--
Dot arrangement	1024×3 (RGB)×768	dots
Color filter array	RGB vertical stripe	--
Display mode	Normally BLACK	--
Viewing Direction	ALL VIEW	--
Module size	260(W)×204(H)×8.6(T)	mm
Active area	245.76(W)×184.32(H)	mm
Dot pitch	0.24(W)×0.24(H)	mm
Interface	LVDS	--
Operating temperature	-30 ~ +85	°C
Storage temperature	-30 ~ +85	°C
Module Weight	520	g



### 3. External Dimensions

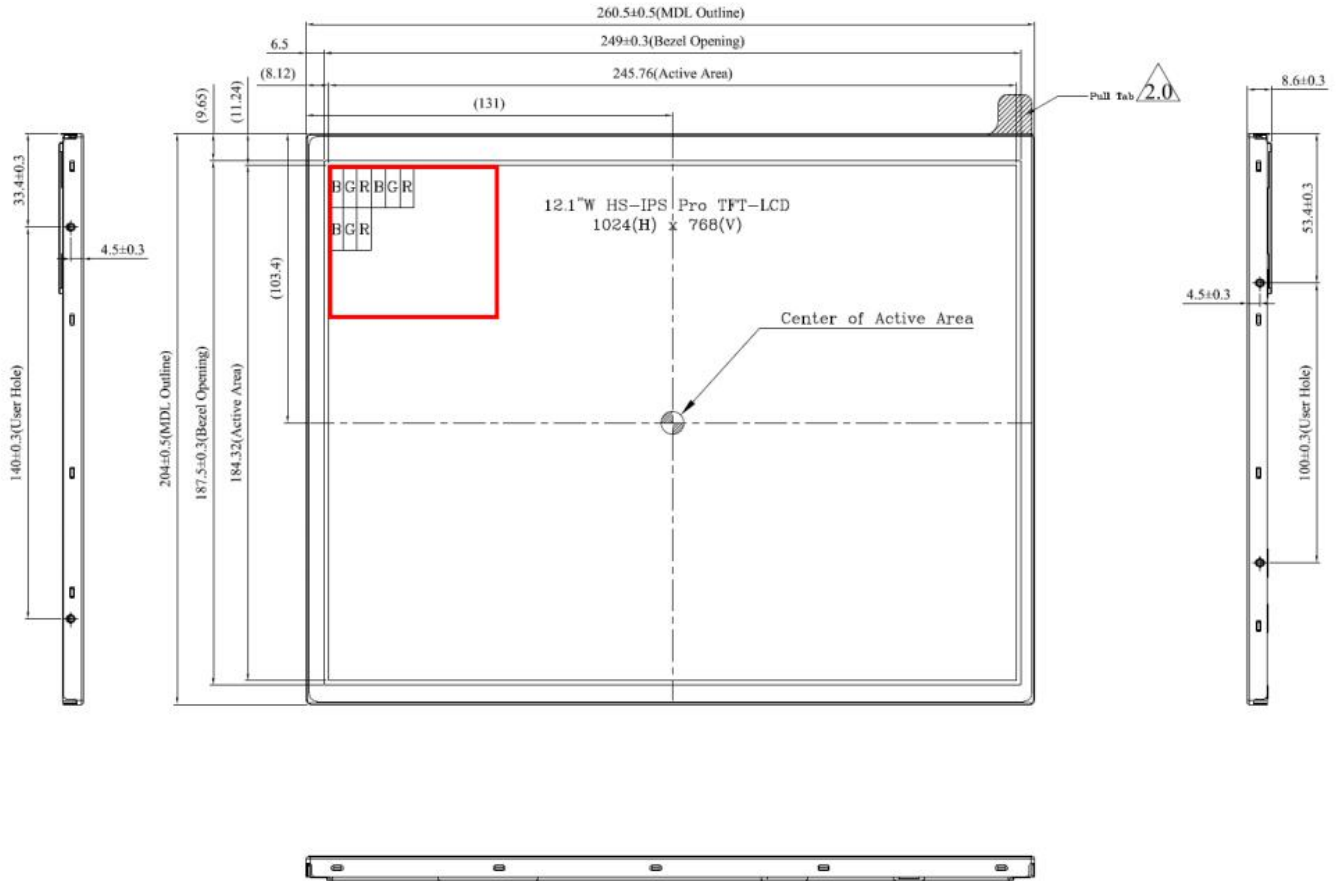

General tolerance: ±0.5mm

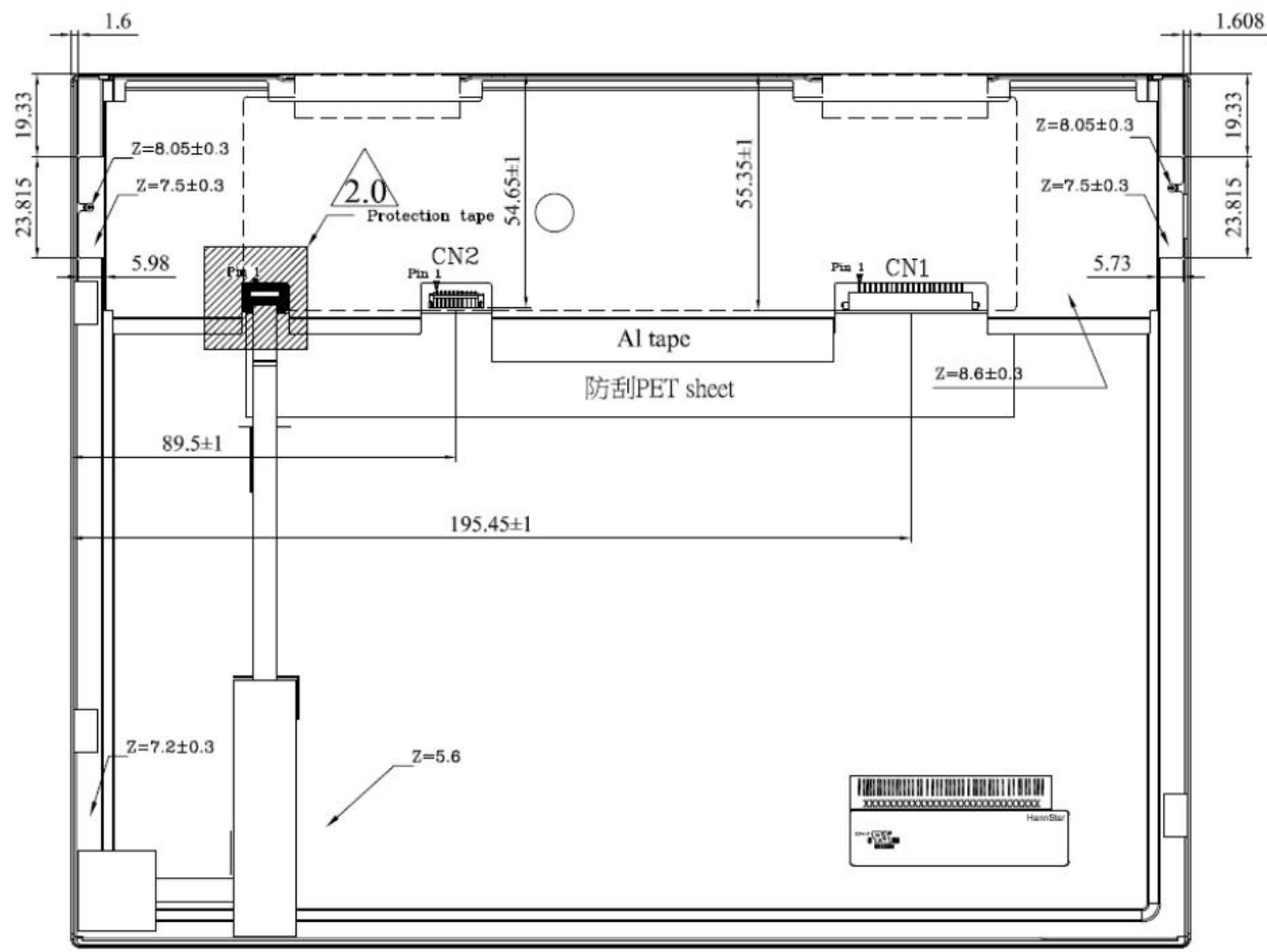



## 4. Interface Description

**LCM CONNECTOR** : STARCONN 076B20-0048RA-G4 or JAE FI-SEB20P-HFE (or equivalent)

No.	Symbol	I/O	Function
1	RXIN3+	I	Positive LVDS differential data inputs
2	RXIN3-	I	Negative LVDS differential data inputs
3	BIST	I	Normal operation/BIST pattern select. BIST="1" : BIST mode. BIST="0" : Normal operation.
4	SELB	I	6bit/8bit mode select H : 8bit / L : 6bit
5	GND	P	Ground
6	RXCLK+	I	Positive LVDS differential clock inputs
7	RXCLK-	I	Negative LVDS differential clock inputs
8	GND	P	Ground
9	RXIN2+	I	Positive LVDS differential data inputs
10	RXIN2-	I	Negative LVDS differential data inputs
11	GND	P	Ground
12	RXIN1+	I	Positive LVDS differential data inputs
13	RXIN1-	I	Negative LVDS differential data inputs
14	GND	P	Ground
15	RXIN0+	I	Positive LVDS differential data inputs
16	RXIN0-	I	Negative LVDS differential data inputs
17	L/R	I	Horizontal inversion
18	U/D	I	Vertical inversion
19, 20	VDD	P	Digital power

I : input , O : output , P : Power

### 【Note】

\*1) : When L/R="0" , set left to right scan direction

When L/R="1" , set right to left scan direction

When U/D="0" , set bottom to top scan direction

When U/D="1" , set top to bottom scan direction

**Backlight pin Assignment(cn2):** ACES 91208-01001-H01 (or equivalent)

No.	Symbol	Description	Function
1~4	Vi	Converter input voltage	12V
5-8	GND	Ground	Ground
9	EN	Enable pin	3.3V
10	ADJ	Backlight Adjust	PWM Dimming (100Hz-30KHz, Hi: 2.0~3.3V,Lo : 0~0.8V)



## 5. ELECTRICAL CHARACTERISTICS

Item	Symbol	Min.	Typ.	Max.	Unit	Note
Supply Voltage	V <sub>DD</sub>	3.0	3.3	3.6	V	
Current of power supply	I <sub>DD</sub>	—	0.25	—	A	V <sub>DD</sub> = 3.3V · white pattern (L255)
VDD Power	P <sub>DD</sub>	—	0.8	1.2	W	V <sub>DD</sub> = 3.3V · white pattern (L255)
Inrush current	I <sub>RUSH</sub>	—	—	2.0	A	Note*

Note\* : Inrush current test circuit and rising time setting (power on)

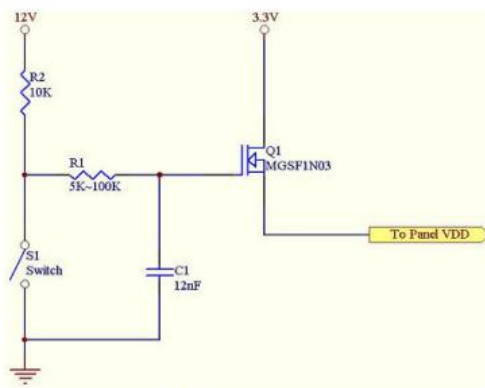

Test circuit

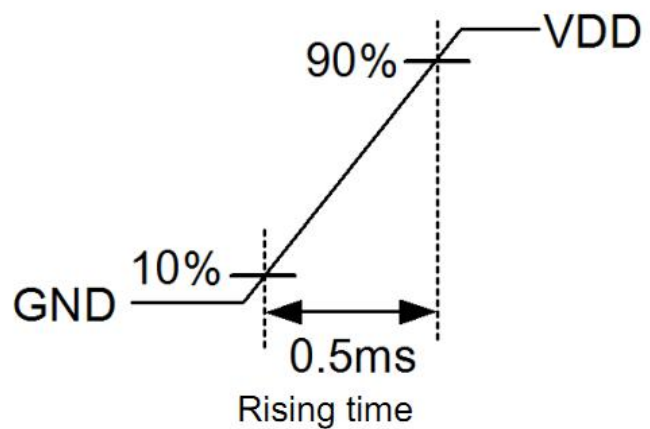

## 6. Switching Characteristics for LVDS Receiver

Item	Symbol	Min.	Typ.	Max.	Unit	Conditions
Differential Input High Threshold	V <sub>TH</sub>	100	-	300	mV	
Differential Input Low Threshold	V <sub>TL</sub>	-300	-	100	mV	
Differential input common mode voltage	V <sub>CM</sub>	1.0	1.2	$\frac{1.7- V_{ID} }{2}$	V	
Input Current	I <sub>IN</sub>	-10	-	10	uA	RX+/-, RXC+/-
Differential input Voltage	V <sub>ID</sub>	200	-	600	mV	





## 7. Timing Characteristics

### 7.1 POWER ON/OFF SEQUENCE

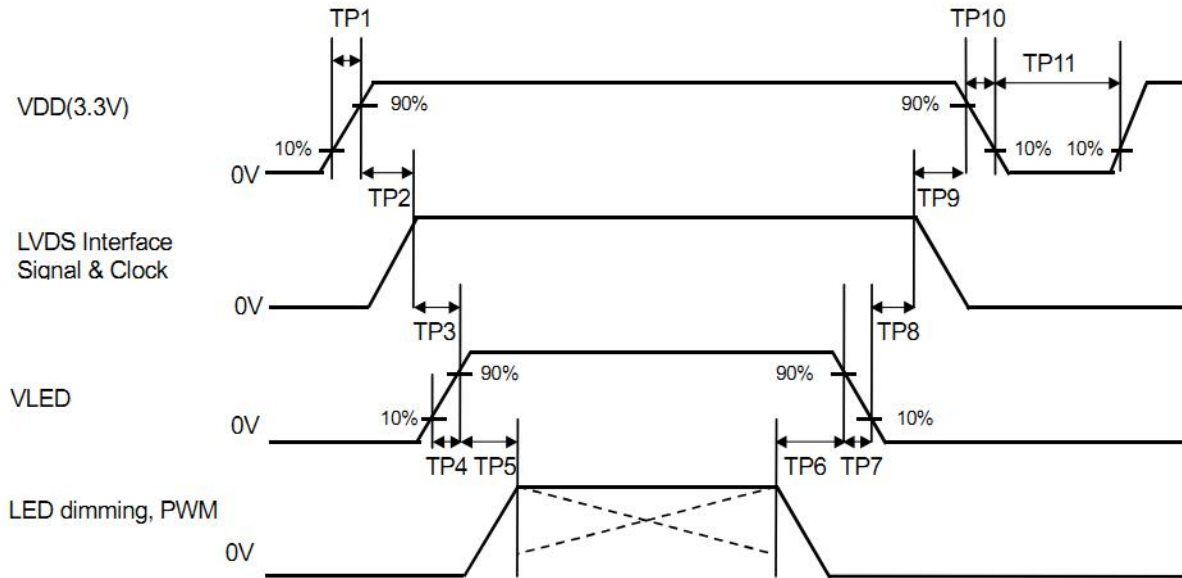

Item	Min.	Typ.	Max.	Unit
TP1	0.5	--	10	msec
TP2	0	--	50	msec
TP3	200	--	--	msec
TP4	0.5	--	10	msec
TP5	10	--	--	msec
TP6	10	--	--	msec
TP7	0	--	10	msec
TP8	200	--	--	msec
TP9	0	--	50	msec
TP10	1	--	10	msec
TP11	1000	--	--	msec



## 7.2 INPUT SIGNAL TIMING

### 7.2.1 LVDS mode data input format

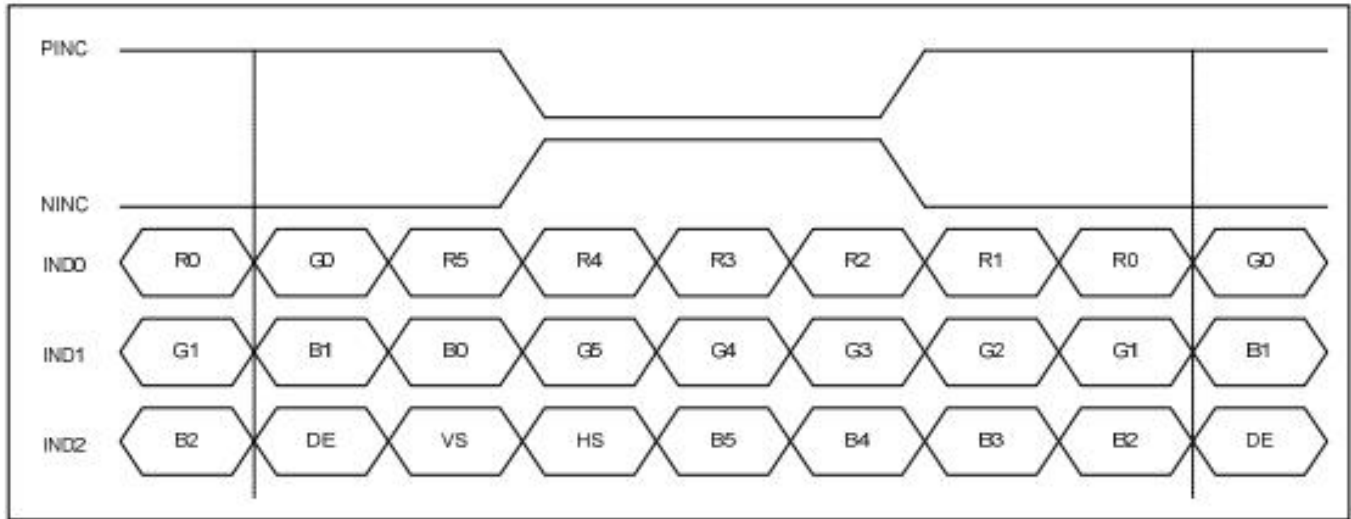

**6-bit LVDS input**

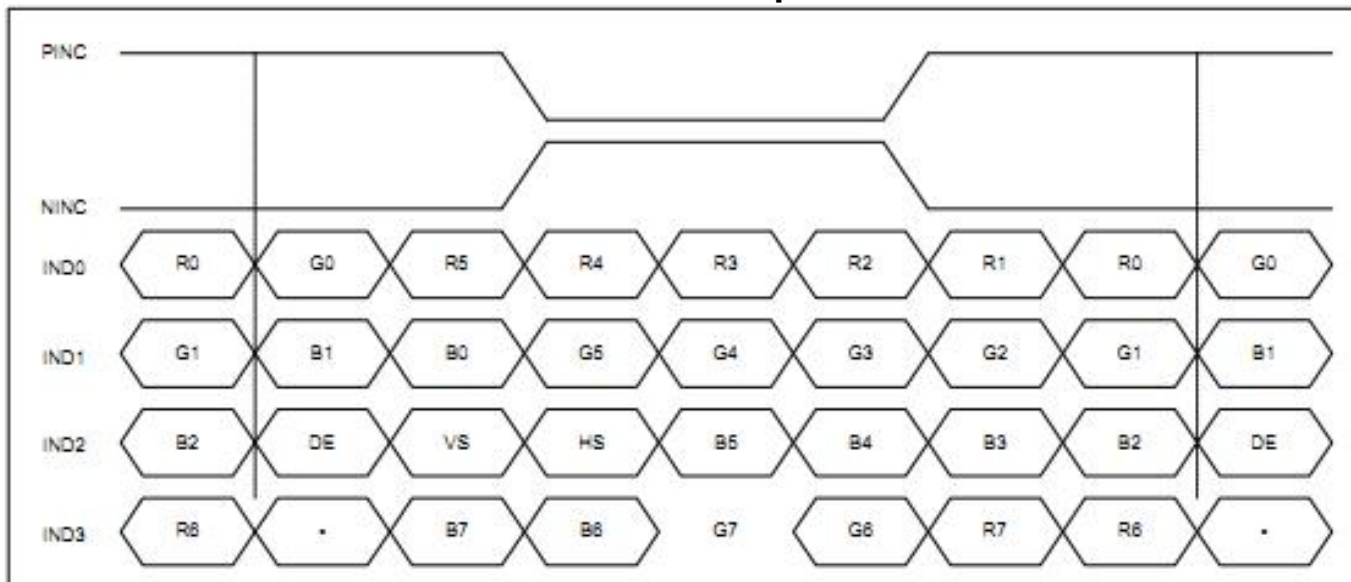

**8-bit LVDS input**

## 7.2 PARALLEL RGB INPUT TIMING TABLE

### DE mode (1024x768)

Item	Symbol	Min.	Typ.	Max.	Unit
Frame Rate	--	59.95	60.05	60.15	Hz
Vertical Total Time	T <sub>V</sub>	774	776	778	line
Vertical Display Time	T <sub>VD</sub>	768			line
Vertical Blanking Time	T <sub>VB</sub>	6	8	10	line
Horizontal Total Time	T <sub>H</sub>	1084	1088	1092	clock
Horizontal Display Time	T <sub>HD</sub>	1024			clock
Horizontal Blanking Time	T <sub>HB</sub>	60	64	68	clock
Clock Rate	1/ T <sub>Clock</sub>	50.3	50.7	51.1	MHz



### Timing Diagram of Interface Signal (DE mode)

#### 1. Vertical

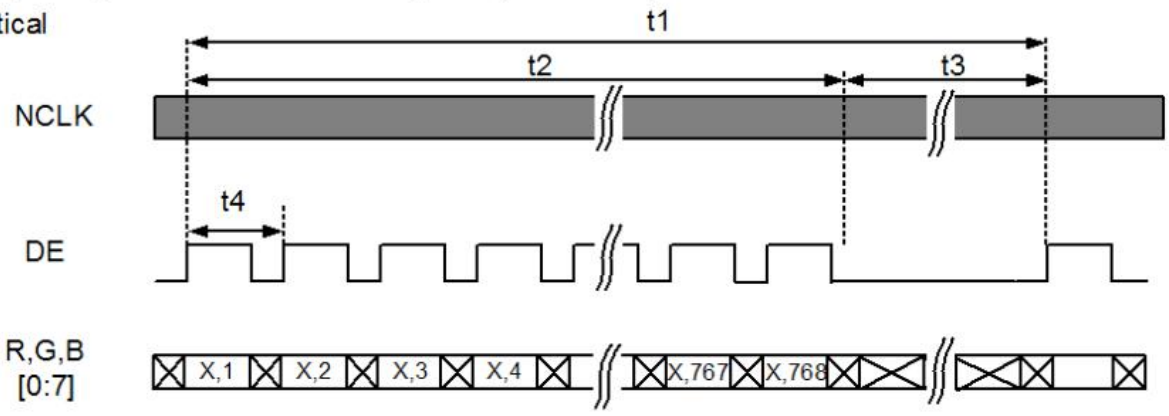

#### 2. Horizontal

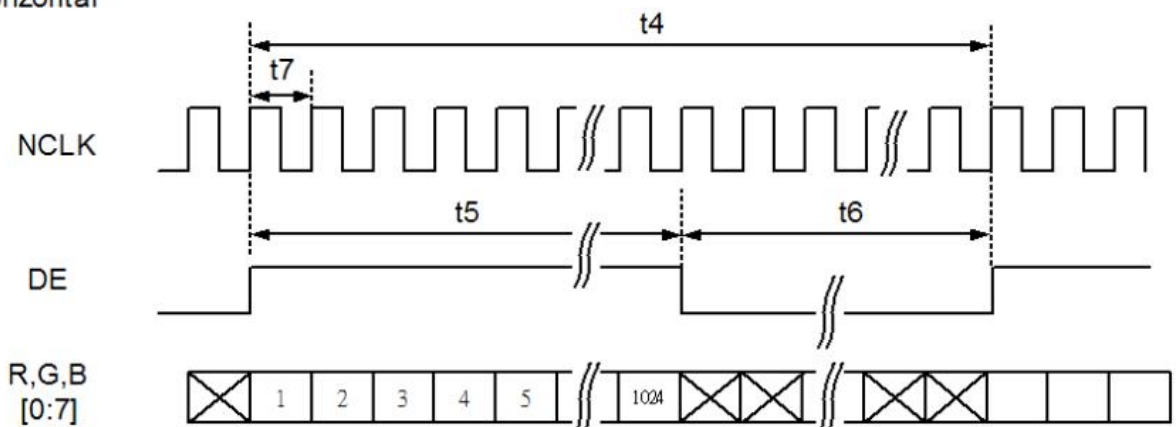



## 8. Backlight Backlight Unit

Item	Symbol	MIN	TYP	MAX	UNIT	Test Condition
Input Current	Vf	10	12	16	Volt	Ta=25°C
Input Voltage	If	-	850	1200	mA	Ta=25°C
White Luminance		400	600		Cd/cm2	850mA
Uniformity for LCM	-	75	-	-	%	Ta=25°C
LED Life-Time	-	30000	50000	-	Hr	Ta=25°C

## Backlight DC Electrical Characteristics

Parameter	Symbol	Min	Typ	Max	Units	Note
Backlight Power Supply	Vi	10	12	16	Volt.	
LED_EN High Threshold	V <sub>ENH</sub>	1.4	3.3	5.0	Volt.	
LED_EN Low Threshold	V <sub>ENL</sub>	0	--	0.8	Volt.	
PWM High Threshold	V <sub>PWMH</sub>	2.0	3.3	6.0	Volt.	
PWM Low Threshold	V <sub>PWML</sub>	0	--	0.8	Volt.	
PWM Frequency	F <sub>PWM</sub>	100	--	30K	Hz	Note (4)
PWM Duty Cycle	T <sub>D</sub>	10	--	100	%	

Note (1) LED life time (Hr) can be defined as the time in which it continues to operate under the condition: Ta=25±3°C, typical IL value indicated in the above table until the brightness becomes less than 50%.

Note (2) The "LED life time" is defined as the module brightness decrease to 50% original brightness at Ta=25°C and I<sub>i</sub>=850mA, the LED lifetime could be decreased if operating IL is larger than 850mA. The constant current driving method is suggested.

Note (3) LED Light Bar Circuit

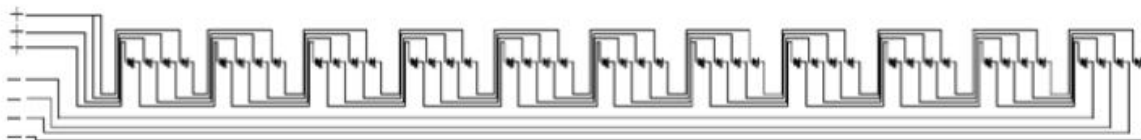

BLU circuit : 11S-4P

Note (4) Dimming controller waveform

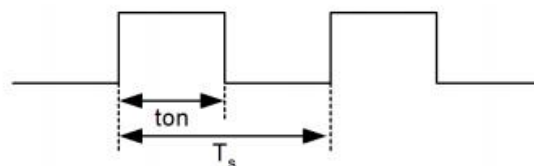

$$T_D = \text{ton} \div T_s \times 100\%$$

$$F_{\text{PWM}} = 1 \div T_s$$



### 9. Optical Characteristics

Item	Conditions	Min.	Typ.	Max.	Unit	Note
Viewing Angle (CR>10)	Horizontal	$\theta_L$	-	85	-	degree  (1),(2),(6)
		$\theta_R$	-	85	-	
	Vertical	$\theta_T$	-	85	-	
		$\theta_B$	-	85	-	
Contrast Ratio	Center	-	900	-	-	(1),(3),(6)
Response Time	Rising + Falling	-	40	-	ms	(1),(4),(6)
CF Color Chromaticity (CIE1931)	Red x	Typ. -0.05	Typ. +0.05	-	-	(1), (6)
	Red y			-		
	Green x			-		
	Green y			-		
	Blue x			-		
	Blue y			-		
	White x			0.290		
	White y			0.325		

Note (1) Measurement Setup: The LCD module should be stabilized at given temp. 25°C for 15 minutes to avoid abrupt temperature change during measuring. In order to stabilize the luminance, the measurement should be executed after lighting backlight for 15 minutes in a windless room.

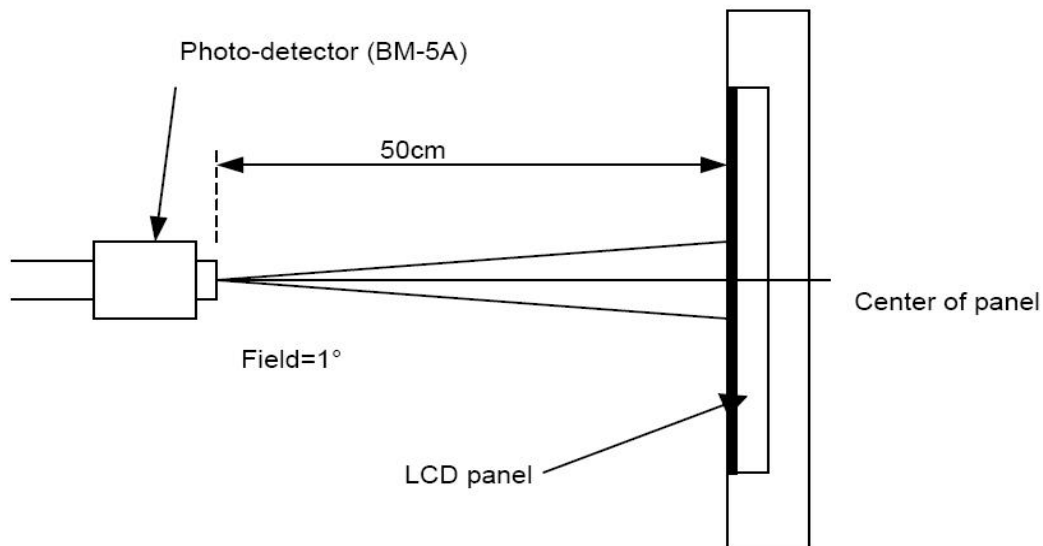



Note (2) Definition of Viewing Angle

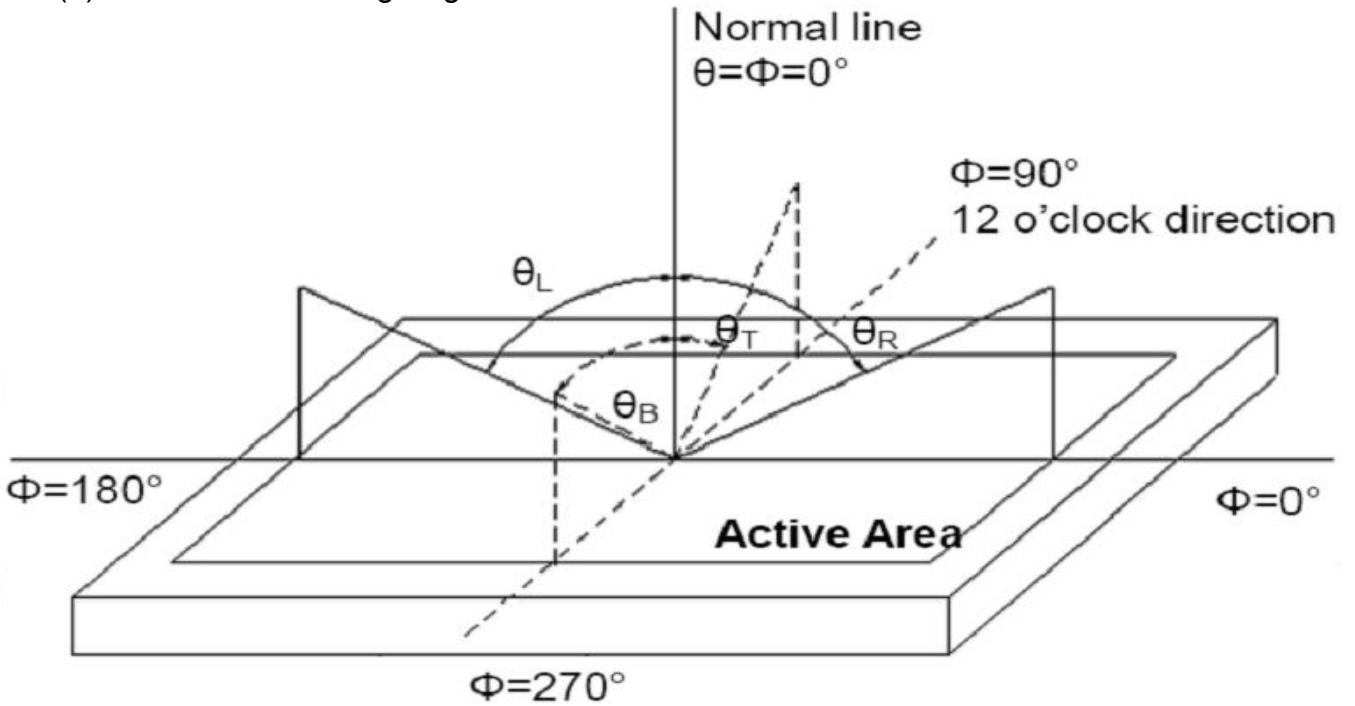

Note (3) Definition of Contrast Ratio (CR)

The contrast ratio can be calculated by the following expression

$$\text{Contrast Ratio (CR)} = L_{63} / L_0$$

L63: Luminance of gray level 63, L0: Luminance of gray level 0

Note (4) Definition of response time

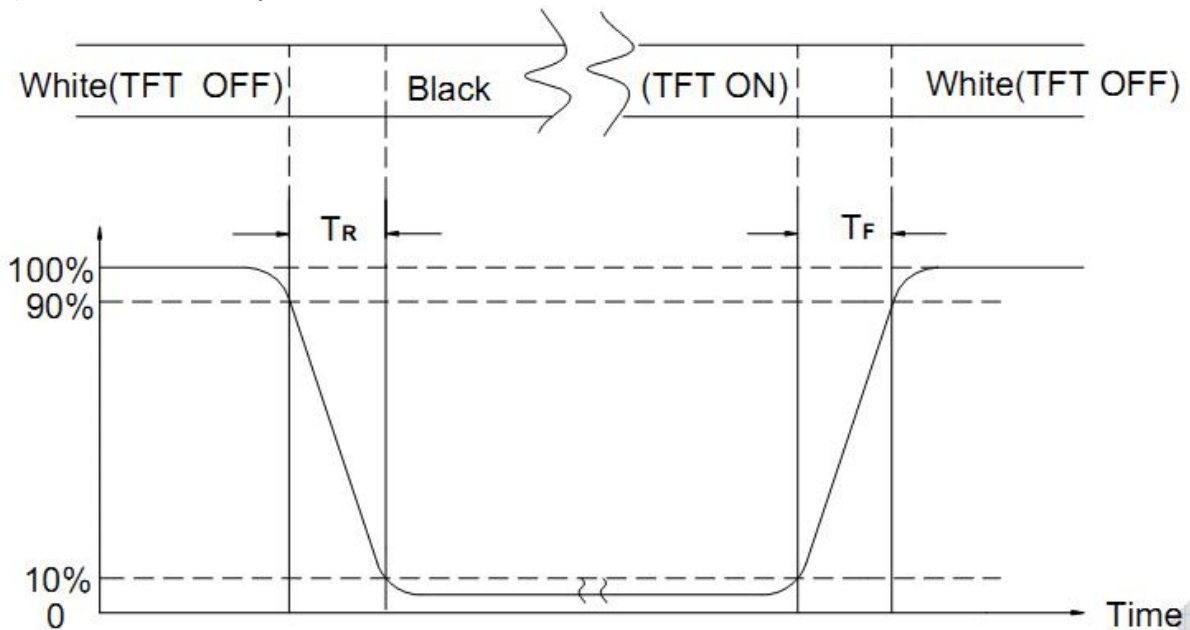

Note (5) Definition of Transmittance (Module is without signal input)

$$\text{Transmittance} = \text{Center Luminance of LCD} / \text{Center Luminance of Back Light} \times 100\%$$

Note (6) Definition of color chromaticity (CIE1931)

Color coordinates measured at the center point of LCD



## 10. Reliability Test Conditions and Methods

No.	Item	Conditions	Remark
1	High Temperature Storage	Ta=+85°C, 240hrs	
2	Low Temperature Storage	Ta=-30°C, 240hrs	
3	High Temperature Operation	Ta=+85°C, 240hrs	
4	Low Temperature Operation	Ta=-30°C, 240hrs	
5	High Temperature and High Humidity (operation)	Ta=+65°C, 90%RH, 240hrs	
6	Thermal Cycling Test (non operation)	-30°C(30min) → +85°C(30min), 500 cycles	
7	Electrostatic Discharge	±200V,200pF(0Ω) 1 time/connector	
8	Vibration	1.Random: 1.04G, 5~500Hz, XYZ, 30min/each direction 2.Sine: Freq.1.5G, 8~33.3Hz, Stoke: 1.3mm Sweep: 2.9G, 33.3~400Hz X/Z: 2hrs, Y: 4hrs	
9	Shock	Half-Sine, 100G, 6ms, ±XYZ, 3time	
10	Vibration (with carton)	Random: 0.015G <sup>2</sup> /Hz, 5~200Hz -6dB/Octave, 200~400Hz XYZ 各方向 2hrs	
11	Drop (with carton)	Drop height condition, basis on the product weight and follow QB100-0027 1 corner, 3 edges, 6 surfaces	

Note: There is no display function NG issue occurred, all the cosmetic specification is judged before the reliability stress.

## 11. Inspection Standard

**11.1. QUALITY :**

THE QUALITY OF GOODS SUPPLIED TO PURCHASER SHALL COME UP TO THE FOLLOWING STANDARD.

**11.1.1. THE METHOD OF PRESERVING GOODS**

AFTER DELIVERY OF GOODS FROM AMSON TO PURCHASER. PURCHASER SHALL CONTROL THE LCM AT -10 °C TO 40°C ,AND IT MIGHT BE DESIRABLE TO KEEP AT THE NORMAL ROOM TEMPERATURE AND HUMIDITY UNTIL INCOMING INSPECTION OR THROWING INTO PROCESS LINE.

**11.1.2. INCOMING INSPECTION****(A) THE METHOD OF INSPECTION**

IF PURCHASER MAKE AN INCOMING INSPECTION , A SAMPLING PLAN SHALL BE APPLIED ON THE CONDITION THAT QUALITY OF ONE DELIVERY SHALL BE REGARDED AS ONE LOT.

**(B) THE STANDARD OF QUALITY**

ISO-2859-1 (SAME AS MIL-STD-105E ) , LEVEL II SINGLE PLAN.

CLASS	AQL(%)
CRITICAL	0.4 %
MAJOR	0.65 %
MINOR	1.5 %
TOTAL	1.5 %

EVERY ITEM SHALL BE INSPECTED ACCORDING TO THE CLASS.

**(C) MEASURE**

IF AS THE RESULT OF ABOVE RECEIVING INSPECTION , A LOT OUT IS DISCOVERED. PURCHASER SHALL BE INFORM SELLER OF IT WITHIN SEVEN DAYS. BUT FIRST SHIPMENT WITHIN FOURTEEN DAYS.

**11.1.3. WARRANTY POLICY**

AMSON WILL PROVIDE ONE-YEAR WARRANTY FOR THE PRODUCTS ONLY IF UNDER SPECIFICATION OPERATING CONDITIONS. AMSON WILL REPLACE NEW PRODUCTS FOR THESE DEFECT PRODUCTS WHICH UNDER WARRANTY PERIOD AND BELONG TO THE RESPONSIBILITY OF AMSON.

**11.2. CHECKING CONDITION**

11.2.1. CHECKING DIRECTION SHALL BE IN THE 45 DEGREE AREA TO FACE THE SAMPLE.

11.2.2. CHECKER SHALL SEE OVER 300±25 mm. WITH BARE EYES FAR FROM SAMPLE AND USING 2 PCS. OF 20W FLUORESCENT LAMP.





### 11.3. INSPECTION PLAN :

CLASS	ITEM	JUDGEMENT	CLASS
PACKING & INDICATE	1. OUTSIDE AND INSIDE PACKAGE	"MODEL NO." , "LOT NO." AND "QUANTITY" SHOULD INDICATE ON THE PACKAGE.	Minor
	2. MODEL MIXED AND QUANTITY	OTHER MODEL MIXED.....REJECTED QUANTITY SHORT OR OVER.....REJECTED	Critical
	3. PRODUCT INDICATION	"MODEL NO." SHOULD INDICATE ON THE PRODUCT	Major
ASSEMBLY	4. DIMENSION, LCD GLASS SCRATCH AND SCRIBE DEFECT.	ACCORDING TO SPECIFICATION OR DRAWING.	Major
APPEARANCE	5. VIEWING AREA	POLARIZER EDGE OR LCD'S SEALING LINE IS VISABLE IN THE VIEWING AREA .....REJECTED	Minor
	6. BLEMISH · BLACK SPOT · WHITE SPOT IN THE LCD AND LCD GLASS CRACKS	ACCORDING TO STANDARD OF VISUAL INSPECTION(INSIDE VIEWING AREA)	Minor
	7. BLEMISH · BLACK SPOT WHITE SPOT AND SCRATCH ON THE POLARIZER	ACCORDING TO STANDARD OF VISUAL INSPECTION(INSIDE VIEWING AREA)	Minor
	8. BUBBLE IN POLARIZER	ACCORDING TO STANDARD OF VISUAL INSPECTION(INSIDE VIEWING AREA)	Minor
	9. LCD'S RAINBOW COLOR	STRONG DEVIATION COLOR ( OR NEWTON RING) OF LCD.....REJECTED. OR ACCORDING TO LIMITED SAMPLE ( IF NEEDED, AND INSIDE VIEWING AREA )	Minor
ELECTRICAL	10. ELECTRICAL AND OPTICAL CHARACTERISTICS ( CONTRAST· VOP · CHROMATICITY ... ETC )	ACCORDING TO SPECIFICATION OR DRAWING . ( INSIDE VIEWING AREA )	Critical
	11.MISSING LINE	MISSING DOT · LINE · CHARACTER .....REJECTED	Critical
	12.SHORT CIRCUIT· WRONG PATTERN DISPLAY	NO DISPLAY · WRONG PATTERN DISPLAY · CURRENT CONSUMPTION OUT OF SPECIFICATION..... REJECTED	Critical
	13. DOT DEFECT (FOR COLOR AND TFT)	ACCORDING TO STANDARD OF VISUAL INSPECTION	Minor



## 11.4. STANDARD OF VISUAL INSPECTION

NO.	CLASS	ITEM	JUDGEMENT																				
11.4.1	MINOR	BLACK AND WHITE SPOT FOREIGN MATERIEL DUST IN THE CELL BLEMISH SCRATCH	<p>(A) ROUND TYPE: <span style="float: right;">unit : mm.</span></p> <table border="1"> <thead> <tr> <th>DIAMETER (mm.)</th> <th>ACCEPTABLE Q'TY</th> </tr> </thead> <tbody> <tr> <td><math>\Phi \leq 0.1</math></td> <td>DISREGARD</td> </tr> <tr> <td><math>0.1 &lt; \Phi \leq 0.25</math></td> <td>3 (Distance&gt;5mm)</td> </tr> <tr> <td><math>0.25 &lt; \Phi</math></td> <td>0</td> </tr> </tbody> </table> <p>NOTE: <math>\Phi = (\text{LENGTH} + \text{WIDTH}) / 2</math></p> <p>(B) LINEAR TYPE: <span style="float: right;">unit : mm.</span></p> <table border="1"> <thead> <tr> <th>LENGTH</th> <th>WIDTH</th> <th>ACCEPTABLE Q'TY</th> </tr> </thead> <tbody> <tr> <td>-----</td> <td><math>W \leq 0.03</math></td> <td>DISREGARD</td> </tr> <tr> <td><math>L \leq 5.0</math></td> <td><math>0.03 &lt; W \leq 0.07</math></td> <td>3 (Distance&gt;5mm)</td> </tr> <tr> <td>-----</td> <td><math>0.07 &lt; W</math></td> <td>FOLLOW ROUND TYPE</td> </tr> </tbody> </table>	DIAMETER (mm.)	ACCEPTABLE Q'TY	$\Phi \leq 0.1$	DISREGARD	$0.1 < \Phi \leq 0.25$	3 (Distance>5mm)	$0.25 < \Phi$	0	LENGTH	WIDTH	ACCEPTABLE Q'TY	-----	$W \leq 0.03$	DISREGARD	$L \leq 5.0$	$0.03 < W \leq 0.07$	3 (Distance>5mm)	-----	$0.07 < W$	FOLLOW ROUND TYPE
DIAMETER (mm.)	ACCEPTABLE Q'TY																						
$\Phi \leq 0.1$	DISREGARD																						
$0.1 < \Phi \leq 0.25$	3 (Distance>5mm)																						
$0.25 < \Phi$	0																						
LENGTH	WIDTH	ACCEPTABLE Q'TY																					
-----	$W \leq 0.03$	DISREGARD																					
$L \leq 5.0$	$0.03 < W \leq 0.07$	3 (Distance>5mm)																					
-----	$0.07 < W$	FOLLOW ROUND TYPE																					
11.4.2	MINOR	BUBBLE IN POLARIZER DENT ON POLARIZER	<p style="text-align: right;">unit : mm.</p> <table border="1"> <thead> <tr> <th>DIAMETER</th> <th>ACCEPTABLE Q'TY</th> </tr> </thead> <tbody> <tr> <td><math>\Phi \leq 0.2</math></td> <td>DISREGARD</td> </tr> <tr> <td><math>0.2 &lt; \Phi \leq 0.5</math></td> <td>2 (Distance&gt;5mm)</td> </tr> <tr> <td><math>0.5 &lt; \Phi</math></td> <td>0</td> </tr> </tbody> </table>	DIAMETER	ACCEPTABLE Q'TY	$\Phi \leq 0.2$	DISREGARD	$0.2 < \Phi \leq 0.5$	2 (Distance>5mm)	$0.5 < \Phi$	0												
DIAMETER	ACCEPTABLE Q'TY																						
$\Phi \leq 0.2$	DISREGARD																						
$0.2 < \Phi \leq 0.5$	2 (Distance>5mm)																						
$0.5 < \Phi$	0																						
11.4.3	MINOR	Dot Defect	<table border="1"> <thead> <tr> <th>Items</th> <th>ACC. Q'TY</th> </tr> </thead> <tbody> <tr> <td>Bright dot</td> <td><math>N \leq 4</math></td> </tr> <tr> <td>Dark dot</td> <td><math>N \leq 4</math></td> </tr> </tbody> </table> <p>Pixel Define :</p> <p>Note 1: The definition of dot: The size of a defective dot over 1/2 of whole dot is regarded as one defective dot.</p> <p>Note 2: Bright dot: Dots appear bright and unchanged in size in which LCD panel is displaying under black pattern.</p> <p>Note 3: Dark dot: Dots appear dark and unchanged in size in which LCD panel is displaying under pure red, green, blue pattern.</p>	Items	ACC. Q'TY	Bright dot	$N \leq 4$	Dark dot	$N \leq 4$														
Items	ACC. Q'TY																						
Bright dot	$N \leq 4$																						
Dark dot	$N \leq 4$																						

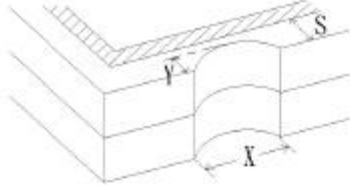
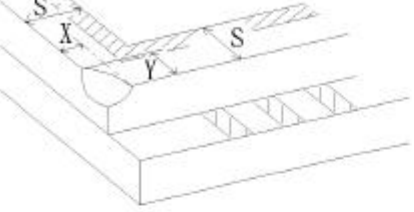
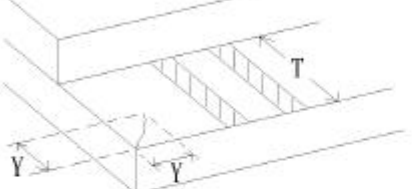
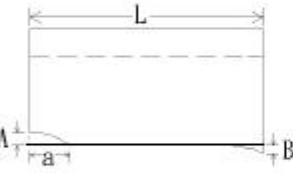
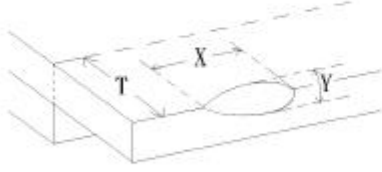
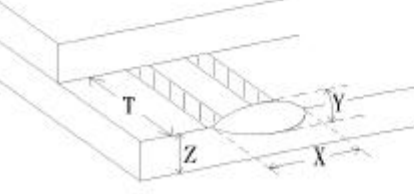
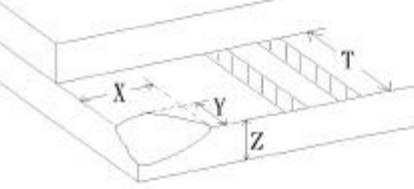

NO.	CLASS	ITEM	JUDGEMENT
11.4.4	MINOR	LCD GLASS CHIPPING	 $Y > S$ Reject
11.4.5	MINOR	LCD GLASS CHIPPING	 $X \text{ or } Y > S$ Reject
11.4.6	MAJOR	LCD GLASS GLASS CRACK	 $Y > (1/2) T$ Reject
11.4.7	MAJOR	LCD GLASS SCRIBE DEFECT	 <ol style="list-style-type: none"> <li><math>a &gt; L/3</math>, <math>A &gt; 1.5\text{mm}</math>. Reject</li> <li>B: ACCORDING TO DIMENSION</li> </ol>
11.4.8	MINOR	LCD GLASS CHIPPING ( ON THE TERMINAL AREA )	 $\Phi = (x+y)/2 > 2.5 \text{ mm}$ Reject
11.4.9	MINOR	LCD GLASS CHIPPING ( ON THE TERMINAL SURFACE )	 $Y > (1/3) T$ Reject
11.4.10	MINOR	LCD GLASS CHIPPING	 $Y > T$ Reject



## 12. Handling Precautions

### 12.1 Mounting method

The LCD panel of KINGTECH TFT module consists of two thin glass plates with polarizers which easily be damaged. And since the module is so constructed as to be fixed by utilizing fitting holes in the printed circuit board.

Extreme care should be needed when handling the LCD modules.

### 12.2 Caution of LCD handling and cleaning

When cleaning the display surface, Use soft cloth with solvent

[Recommended below] and wipe lightly

- Isopropyl alcohol
- Ethyl alcohol

Do not wipe the display surface with dry or hard materials that will damage the polarizer surface.

Do not use the following solvent:

- Water
- Aromatics

Do not wipe ITO pad area with the dry or hard materials that will damage the ITO patterns

Do not use the following solvent on the pad or prevent it from being contaminated:

- Soldering flux
- Chlorine (Cl) , Sulfur (S)

If goods were sent without being silicon coated on the pad, ITO patterns could be damaged due to the corrosion as time goes on.

If ITO corrosion happens by miss-handling or using some materials such as Chlorine (Cl), Sulfur (S) from customer, Responsibility is on customer.

### 12.3 Caution against static charge

The LCD module uses C-MOS LSI drivers, so we recommend that you:

Connect any unused input terminal to POWER or GROUND, do not input any signals before power is turned on, and ground your body, work/assembly areas, and assembly equipment to protect against static electricity.

### 12.4 packing

- Module employs LCD elements and must be treated as such.
- Avoid intense shock and falls from a height.
- To prevent modules from degradation, do not operate or store them exposed directly to sunshine or high temperature/humidity

### 12.5 Caution for operation

- It is an indispensable condition to drive LCD's within the specified voltage limit since the higher voltage than the limit causes the shorter LCD life.
- An electrochemical reaction due to direct current causes LCD's undesirable deterioration, so that the use of direct current drive should be avoided.
- Response time will be extremely delayed at lower temperature than the operating temperature range and on the other hand at higher temperature LCD's show dark color in them. However those phenomena do not mean malfunction or out of order with LCD's, which will come back in the specified operation temperature.
- If the display area is pushed hard during operation, some font will be abnormally displayed but it resumes normal condition after turning off once.
- Slight dew depositing on terminals is a cause for electro-chemical reaction resulting in terminal open circuit.

Usage under the maximum operating temperature, 50%Rh or less is required.



## 12.6 storing

In the case of storing for a long period of time for instance, for years for the purpose or replacement use, the following ways are recommended.

- Storage in a polyethylene bag with the opening sealed so as not to enter fresh air outside in it. And with no desiccant.
- Placing in a dark place where neither exposure to direct sunlight nor light's keeping the storage temperature range.
- Storing with no touch on polarizer surface by the anything else.  
[It is recommended to store them as they have been contained in the inner container at the time of delivery from us

## 12.7 Safety

- It is recommendable to crash damaged or unnecessary LCD's into pieces and wash off liquid crystal by either of solvents such as acetone and ethanol, which should be burned up later.
- When any liquid leaked out of a damaged glass cell comes in contact with your hands, please wash it off well with soap and water

## 13. Precaution for Use

### 13.1

A limit sample should be provided by the both parties on an occasion when the both parties agreed its necessity. Judgment by a limit sample shall take effect after the limit sample has been established and confirmed by the both parties.

### 13.2

On the following occasions, the handing of problem should be decided through discussion and agreement between responsible of the both parties.

- When a question is arisen in this specification
- When a new problem is arisen which is not specified in this specifications
- When an inspection specifications change or operating condition change in customer is reported to KINGTECH TFT , and some problem is arisen in this specification due to the change
- When a new problem is arisen at the customer's operating set for sample evaluation in the customer site.



### 14. Packing Method

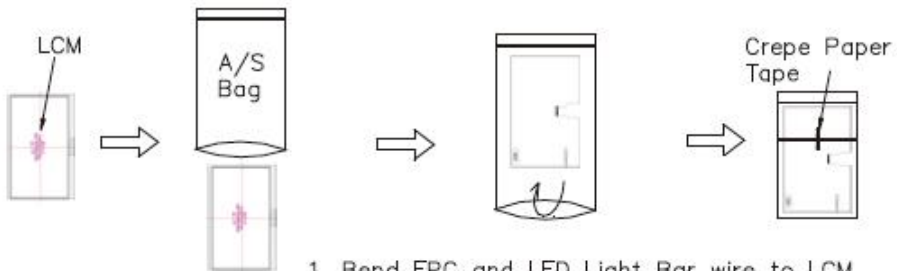

1. Bend FPC and LED Light Bar wire to LCM backside.
2. Fix with crepe paper tape .
3. Put LCM into A/S BAG .

Partition + Corrugated Bar\*2 

Corrugated paper

DUST-PROOF-BAG 

Corrugated Bar\*2 