

CUSTOMER:

QSPI接口

PIN	Description
1	GND
2	LEDK
3	GND
4	LEDA
5	LCD_A0
6	LCD_TE
7	LCD_CS
8	LCD_RST
9	LCD_CLK
10	LCD_D3
11	LCD_D2
12	LCD_D1
13	LCD_D0
14	VDDIO
15	GND

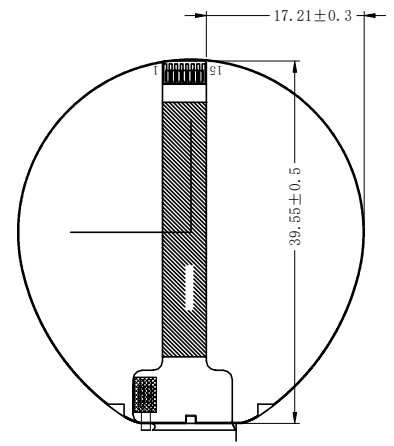
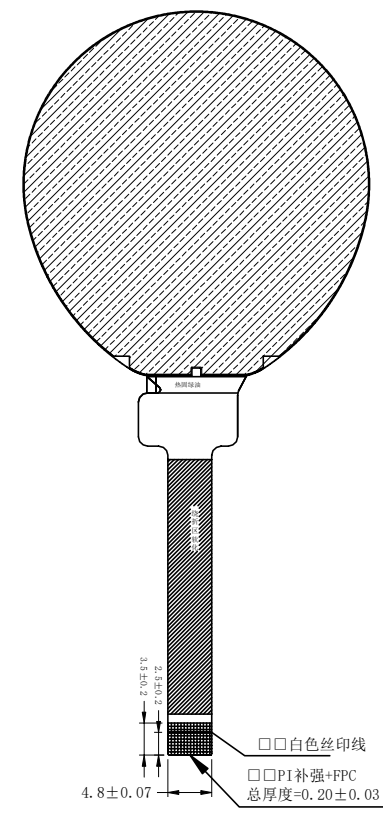
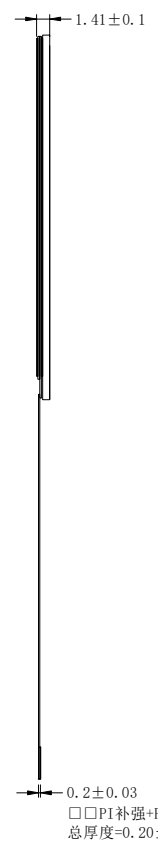
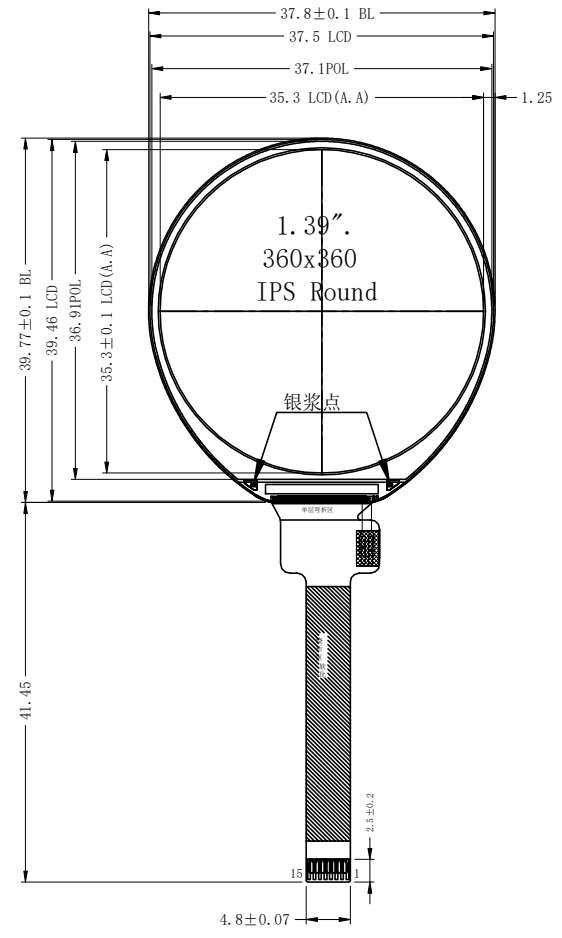

- 技术要求:
- 带*尺寸为重点尺寸, 带 () 尺寸为参考尺寸
 - LCD切割断面崩边 $\leq 1/3$ (单层LCD厚度)
 - 平面翘曲度 $\leq 0.2\text{mm}$
 - 符合RoHS指令
 - 工作温度: $-20^{\circ}\text{C} \sim 70^{\circ}\text{C}$
 - 储存温度: $-30^{\circ}\text{C} \sim 80^{\circ}\text{C}$
 - 建议TP V.A开窗比LCD A.A单边大0.4mm
 - 泡棉开窗比LCD A.A单边大0.3mm
 - 背光均匀度 $>80\%$ (九宫格9点测试), 试产&样品 $>85\%$

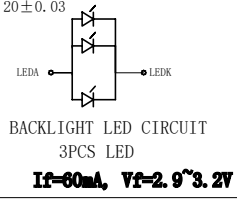

LCD型号/类型/分辨率	1.39 TFT IPS
视角方向	ALL
偏光片	上细砂/下增片
驱动IC/是否带RAM	GC9B71
接口类型	QSPI
LED颗数/连接方式/电流	3-LED
亮度	TBD

修改记录

序号	修改内容	日期
A1	按照客户要求设计	Anmi 2022.7.7

名称

Kingtech Group Co.,Ltd.

TOLERANCE:	PRODUCT NO. PV13907Y0515K	DRAW NO. LCM	REV A1
DECIMAL .xx ± .20 $\leq \pm 1/4^{\circ}$	DWN:	DSN:	APPD:
CHKD:	NOT IN SCALE	UNIT: mm	SHEET: 1-1