





SPECIFICATION

Product Model: PV07042Y0140T

DESIGNED	CHECKED	Approved
		

Ok

NG, Problem survey

Approved By _____



Table of Contents

List	Description	Page No.
	Cover	1
	Revision Record	2
	Table of Contents	3
1	Scope	4
2	General Information	4
3	External Dimensions	5
4	Interface Description	6
5	Absolute Maximum Ratings	7
6	DC Characteristics	7
7	Timing Characteristics	8
8	Backlight Characteristics	13
9	Optical Characteristics	14
10	Reliability Test Conditions and Methods	16
11	Inspection Standard	17
12	Handling Precautions	21
13	Precaution for Use	22
14	Packing Method	23



1. Scope

This specification defines general provisions as well as inspection standards for TFT module supplied by Kingtech Group Co.,Ltd.

If the event of unforeseen problem or unspecified items may occur, naturally shall negotiate and agree to solution.

2. General Information

TITEM	STANDARD VALUES	UNITS
LCD type	7.0" TFT	--
Dot arrangement	800(RGB)×480	dots
Color filter array	RGB vertical stripe	--
Display mode	Normally White	-
Gray Scale Inversion Direction	6 o'clock	--
Eyes Viewing Direction	40/60/60/60 / 50/70/70/70	
Module size	165.0(W)×104.44(H)×5.2(T)	mm
Active area	152.4 (W)×91.44H)	mm
Dot pitch	190.5(W)×190.5(H)	um
Interface	RGB 18bit	--
Operating temperature	-20 ~ +70	°C
Storage temperature	-30 ~ +80	°C
Back Light	24White LED	--
Weight	TBD	g



3. External Dimensions

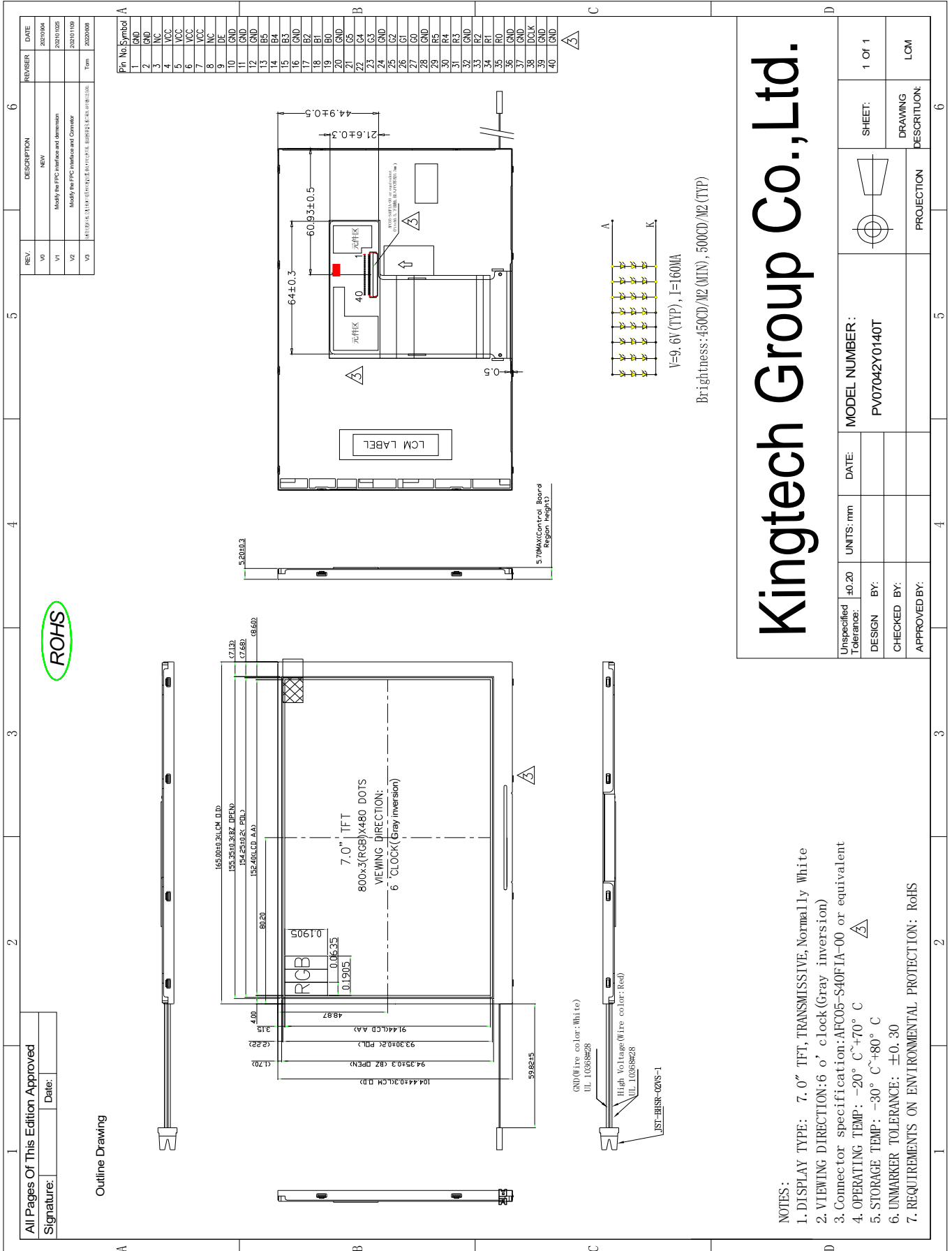

Kingtech Group Co., Ltd.

Unspecified Tolerance:	±0.20	UNITS:mm	DATE:	MODEL NUMBER:	1 Of 1
DESIGN BY:				PV07042Y0140T	
CHECKED BY:					
APPROVED BY:					
PROJECTION				DRAWING DESCRIPTION:	LCM



4. Interface Description

PIN	PIN NAME	DESCRIPTION
1	GND	Power ground
2	GND	
3	NC	Not connect
4	VCC	Digital Power.
5	VCC	
6	VCC	
7	VCC	
8	NC	Not connect
9	DE	Data Enable signal.
10	GND	Power ground
11	GND	
12	GND	
13	B5	Blue Data Input.
14	B4	Blue Data Input.
15	B3	Blue Data Input.
16	GND	Power ground
17	B2	Blue Data Input.
18	B1	Blue Data Input.
19	B0	Blue Data Input
20	GND	Power ground
21	G5	Green Data Input.
22	G4	Green Data Input.
23	G3	Green Data Input.
24	GND	Power ground
25	G2	Green Data Input.
26	G1	Green Data Input.
27	G0	Green Data Input
28	GND	Power ground
29	R5	Red Data Input.
30	R4	Red Data Input.
31	R3	Red Data Input.
32	GND	Power ground
33	R2	Red Data Input.
34	R1	Red Data Input.
35	R0	Red Data Input
36	GND	Power ground.
37	GND	
38	DCLK	Clock input.
39-40	GND	Power ground.



5. Absolute Maximum Ratings

Item	Symbol	Min.	Max.	Unit
Logic Supply Voltage	DVDD	-0.5	5	V
Analog Supply Voltage	AVDD	-0.5	15	V
High Supply Voltage	VGH	-0.3	40	V
Low Supply Voltage	VGL	-20	0.3	V
Operating Temperature	TOP	-20	70	°C
Storage Temperature	TST	-30	80	°C

6. Operating Conditions

Parameter	Symbol	Rating			Unit	Condition	
		Min.	Typ.	Max.			
Power Supply Voltage	V _{CC}	3.0	3.3	3.6	V		
	AVDD	10.2	10.4	10.6	V		
	V _{GH}	15.3	16	16.7	V		
	V _{GL}	-7.7	-7	-6.3	V		
Input Signal Voltage	V _{COM}	-	5.1	-	V		
LCD power current	I _{CC}	--	210		mA	black pattern	
Digital Input Voltage	High Level	V _{IH}	0.7V _{CC}	-	V _{CC}	V	Note 1
	Low Level	V _{IL}	0	-	0.3V _{CC}	V	Note 1

Note 1: DCLK, HS, VS, RESET, U/D, L/R, DE, R0~R7, G0~G7, B0~B7, MODE, DITHB.

Note 1: Please adjust VCOM to make the flicker level be minimum. Typ VCOM 电压值
只做参考, 具体以实际效果为准 (根据 FLICKER 状态可调整)



7. Timing Characteristics

7.1 DC Characteristics

Parameter	Symbol	Condition	Rating			Unit	Application pin
			Min.	Typ.	Max.		
Input H voltage	V_{IH}	-	0.7VCC	-	VCC	V	All input
Input L voltage	V_{IL}	-	0	-	0.3VCC	V	All input
Output H voltage	V_{OH}	$I_{OH}=200\mu A$	VCC-0.3	-	VCC	V	STVU,D
Output L voltage	V_{OL}	$I_{OL}=200\mu A$	0	-	0.3	V	STVU,D
Output H resistance	R_{OH}	$V_x = V_{GH} - 0.5V$	-	-	1000	Ω	OUT[1] ~ OUT[960]
Output L resistance	R_{OL}	$V_x = V_{GL} + 0.5V$	-	-	1000	Ω	OUT[1] ~ OUT[960]
Input leakage current	I_{IN}	-	-1.0	-	+1.0	μA	Note ⁽²⁾
Pull high / low resistance	R_{PHL}	$V_{IN}=GND$ $V_{IN}=VCC$	70	200	400	k Ω	XON, SEL, ,MODE
VGH Power consumption	I_{VGH}	Note ⁽¹⁾	-	-	200	μA	-
VGL Power consumption	I_{VGH}	Note ⁽¹⁾	-	-	-200	μA	-
VCC Power consumption	I_{VCC}	Note ⁽¹⁾	-	-	150	μA	-

Note 1: Power consumption with the following condition: Output no load, $V_{GH}=25V$, $V_{GL}=-15V$, $VCC=3.3V$, $V_{IH}=VCC$, $V_{IL}=V_{GND}$, $F_{CKV} = 60 KHz$, $OE = V_{IL}$, $XON=V_{IH}$.

Note 2: All input except XON, SEL, MODE

7.1 AC Characteristics

Parameter	Symbol	Condition	Rating			Unit
			Min.	Typ.	Max.	
CKV period	t_{CKV}	-	5	-	-	μs
CKV pulse width	t_{CKVH}, t_{CKVL}	50% duty cycle	2.5	-	-	μs
OE pulse width	t_{WOE}	-	1	-	-	μs
XON pulse width	t_{WXAO}	-	100	-	-	μs
Data setup time	t_{SU}	-	0.2	-	-	μs
Data hold time	t_{HD}	-	0.3	-	-	μs
CKV to output delay time	t_{PD1}	CL=200pF	-	-	0.9	μs
Start pulse output delay time	t_{PD2}	CL=20pF	-	-	0.5	μs
OE to output delay time	t_{PD3}	CL=200pF	-	-	0.9	μs
XON to output delay time	t_{PD4}	CL=200pF	-	-	100	μs

Note 1: The measurement point for all of above signals is at 50% of input/output amplitude.



7.2 INPUT SIGNAL TIMING

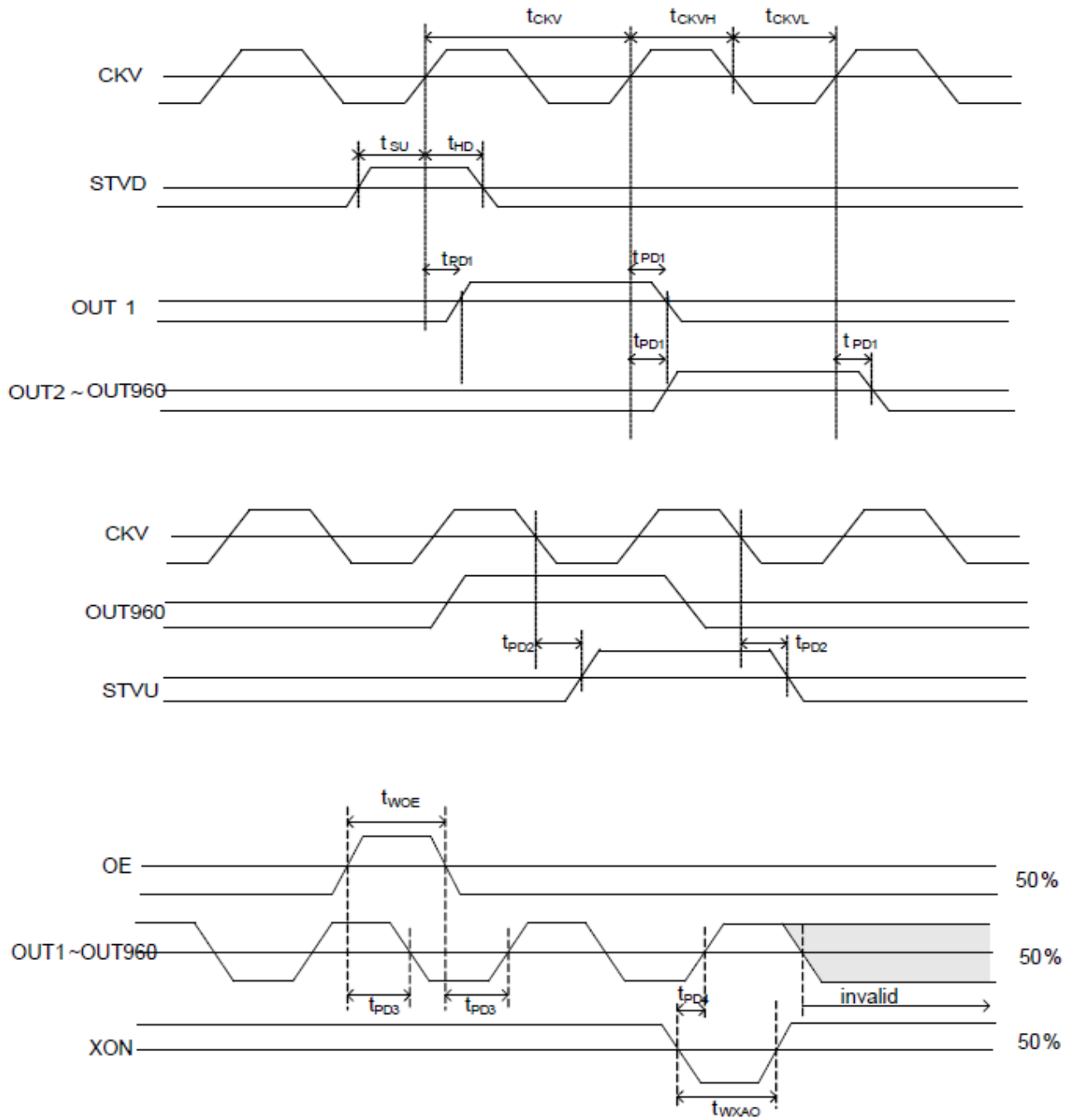



7.3 PARALLEL RGB INPUT TIMING TABLE

Item	Symbol	Values			Unit	Remark
		Min.	Typ.	Max.		
Horizontal Display Area	thd	-	800	-	DCLK	
DCLK Frequency	fclk	26.4	33.3	46.8	MHz	
One Horizontal Line	th	862	1056	1200	DCLK	
HS pulse width	thpw	1	6	40	DCLK	
HS Blanking	thb	46	46	46	DCLK	
HS Front Porch	thfp	16	204	354	DCLK	

Item	Symbol	Values			Unit	Remark
		Min.	Typ.	Max.		
Vertical Display Area	tvd	-	480	-	TH	
VS period time	tv	510	525	650	TH	
VS pulse width	tvpw	1	3	20	TH	
VS Blanking	tvb	23	23	23	TH	
VS Front Porch	tvfp	7	22	147	TH	

Note: Frame rate is $60 \pm 5\text{Hz}$



7.4 Data Input Format

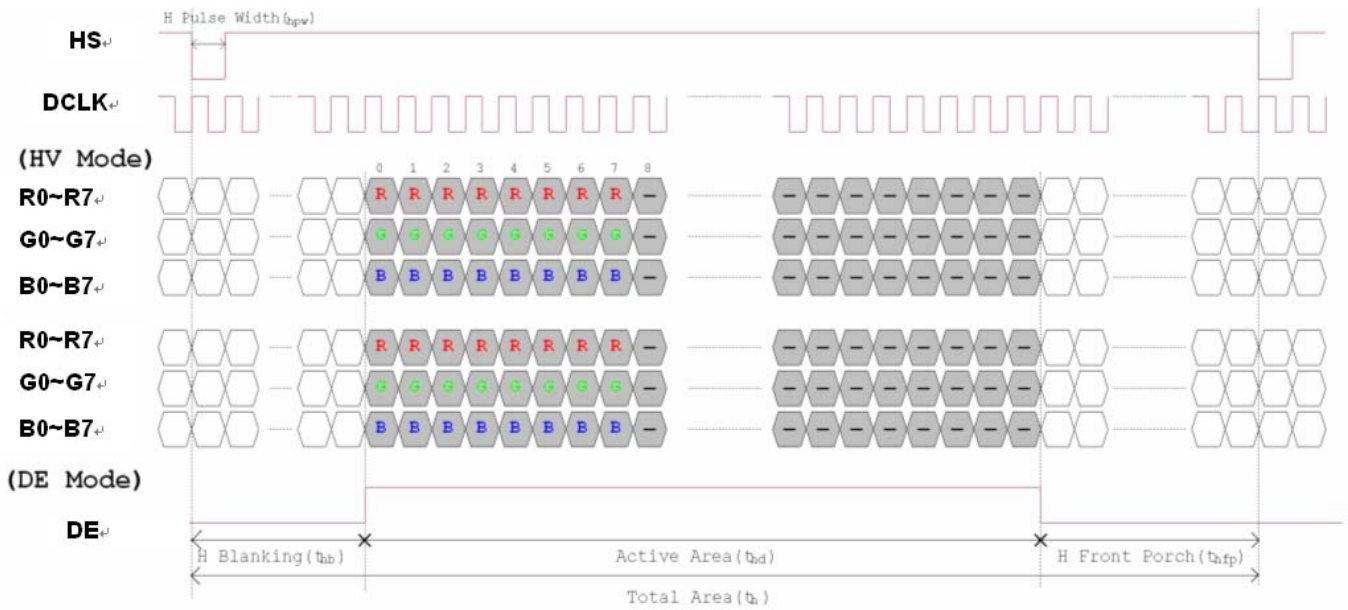

Figure 3. 1 Horizontal input timing diagram.

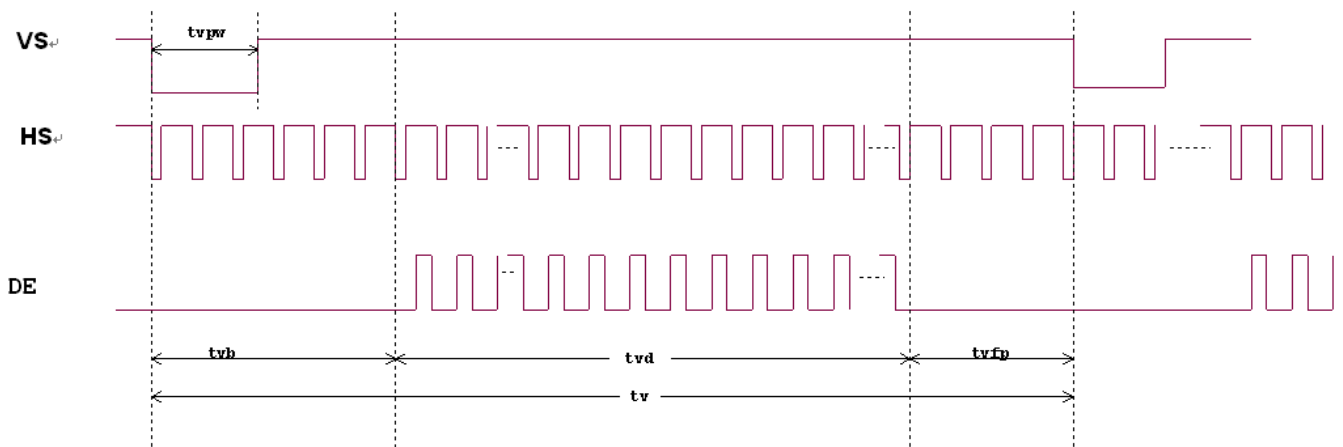
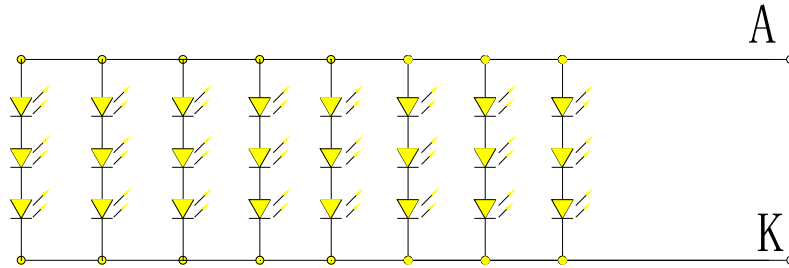

Figure 3. 2 Vertical input timing diagram.



8. Backlight Characteristics



$$V=9.6V(TYP), I=160MA$$

Item	Symbol	MIN	TYP	MAX	UNIT	Test Condition
Supply Voltage	Vf	8.4	9.6	10.5	V	If=270mA
Supply Current	If	-	160	-	mA	-
Luminous Intensity for LCM	-	450	500	-	cd/m ²	If=270mA
Uniformity for LCM	-	75	80	-	%	If=270mA
Life Time	-	-	30000	-	Hr	If=270mA
Backlight Color	White					

9. Optical Characteristics

Item	Conditions	Min.	Typ.	Max.	Unit	Note	
Viewing Angle (CR>10)	Horizontal	θL	60	70	-	degree	(1),(2),(6)
		θR	60	70	-		
	Vertical	θT	50	60	-		
		θB	60	70	-		
Contrast Ratio	Center	700	1000	-	-	(1),(3),(6)	
Response Time	Rising	-	5	10	ms	(1),(4),(6)	
	Falling	-	15	20			
CF Color Chromaticity (CIE1931)	Red x	Typ. -0.05	TBD	Typ. +0.05	-	(1), (6)	
	Red y		TBD		-		
	Green x		TBD		-		
	Green y		TBD		-		
	Blue x		TBD		-		
	Blue y		TBD		-		



	White x		TBD		-
	White y		TBD		-

Note (1) Measurement Setup: The LCD module should be stabilized at given temp. 25°C for 15 minutes to avoid abrupt temperature change during measuring. In order to stabilize the luminance, the measurement should be executed after lighting backlight for 15 minutes in a windless room.

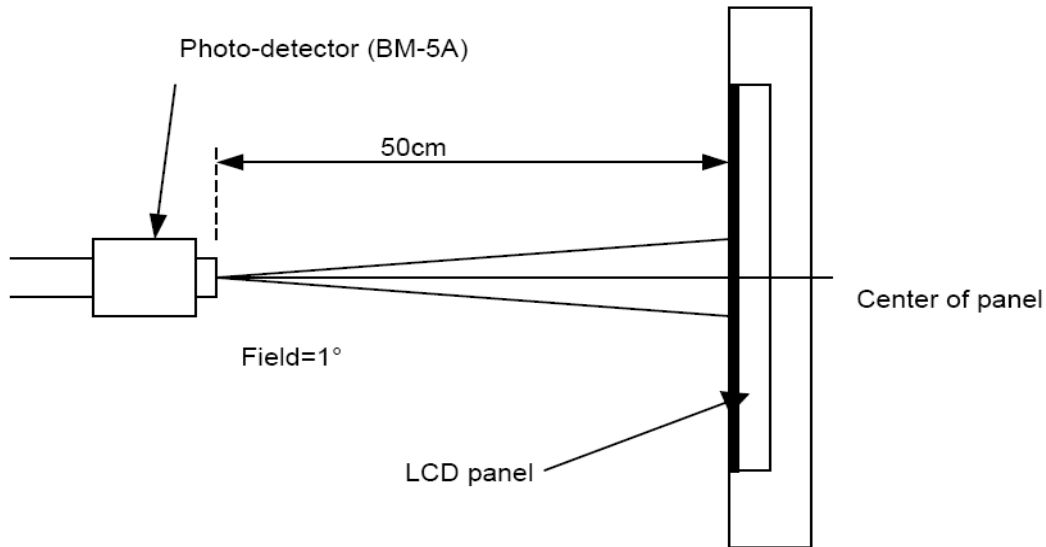

Note (2) Definition of Viewing Angle

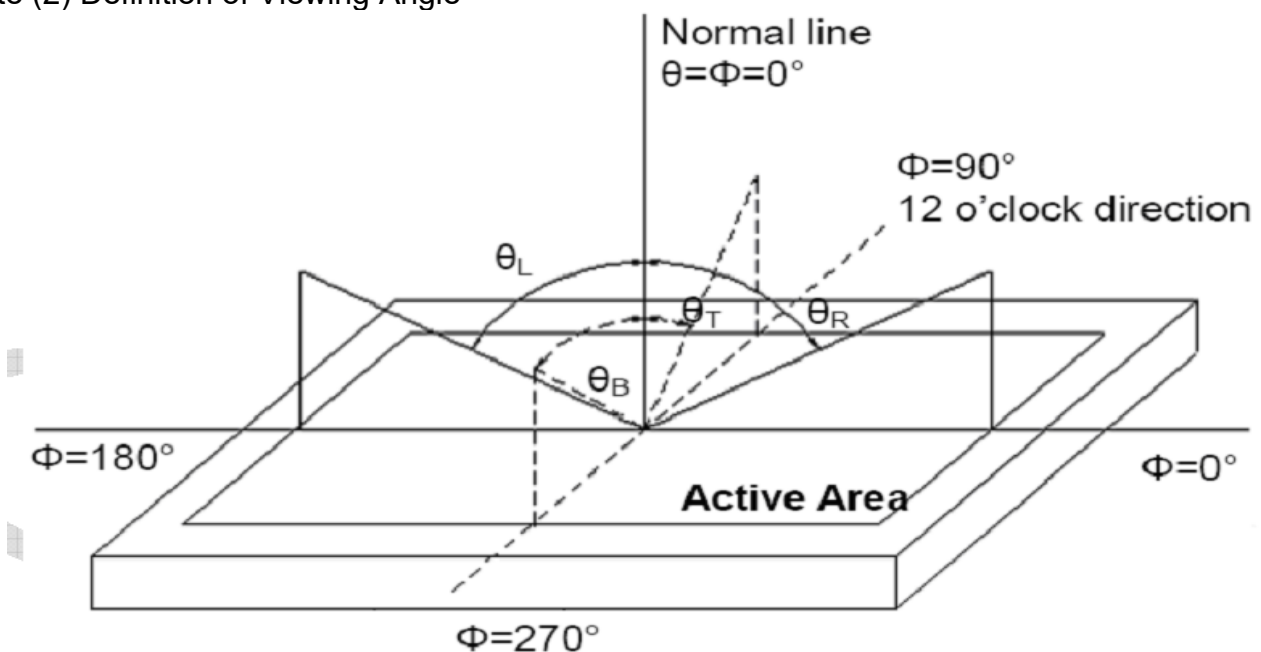



Note (3) Definition of Contrast Ratio (CR)

The contrast ratio can be calculated by the following expression

$$\text{Contrast Ratio (CR)} = L63 / L0$$

L63: Luminance of gray level 63, L0: Luminance of gray level 0

Note (4) Definition of response time

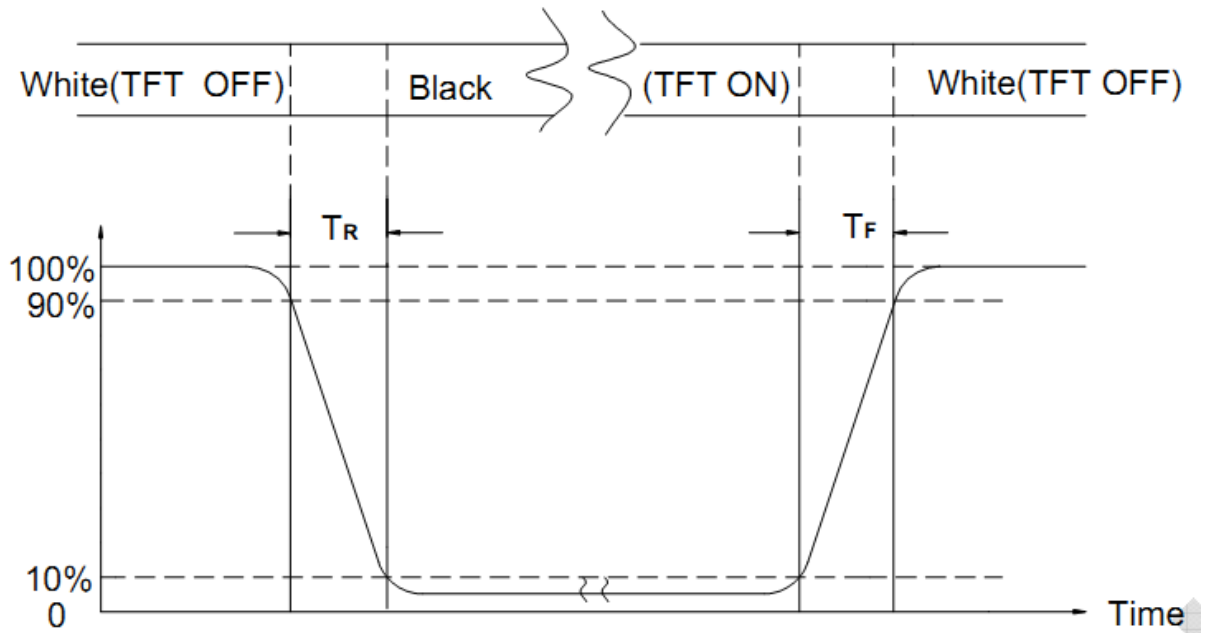

Note (5) Definition of Transmittance (Module is without signal input)

$$\text{Transmittance} = \text{Center Luminance of LCD} / \text{Center Luminance of Back Light} \times 100\%$$

Note (6) Definition of color chromaticity (CIE1931)

Color coordinates measured at the center point of LCD

Note (7) Transmittance is the Value with WV Polarizer and BLU

10. Reliability Test Conditions and Methods



NO.	TEST ITEMS	TEST CONDITION
1	High Temperature Storage	Keep in 80°C ±5°C 96 hrs Surrounding temperature, then storage at normal condition 4hrs.
3	Low Temperature Storage	Keep in -30°C ±5°C 96 hrs Surrounding temperature, then storage at normal condition 4hrs.
3	High Temperature / High Humidity Storage Test	Keep in 60 °C / 90% R.H duration for 96 hrs Surrounding temperature, then storage at normal condition 4hrs. (Excluding the polarizer)
4	Temperature Cycling Storage Test	$ \begin{array}{ccccccc} -30^{\circ}\text{C} & \rightarrow & +25^{\circ}\text{C} & \rightarrow & 80^{\circ}\text{C} & \rightarrow & +25^{\circ}\text{C} \\ (30\text{mins}) & & (5\text{mins}) & & (30\text{mins}) & & (5\text{mins}) \\ \leftarrow & & & & & & \rightarrow \\ & & & & & & 30 \text{ Cycle} \end{array} $ Surrounding temperature, then storage at normal condition 4hrs.
5	Vibration Test (Packaged)	1. Sine wave 10 ~ 55 Hz frequency (1 min/sweep) 2. The amplitude vibration :1.5 mm 3. Each direction (X、 Y、 Z) duration for 2 Hrs
6	Drop Test (Packaged)	Drop Height:45cm Drop Direction :※ 1 corner / 3 edges / 6 sides each 1time



11. Inspection Standard

11.1. QUALITY :

THE QUALITY OF GOODS SUPPLIED TO PURCHASER SHALL COME UP TO THE FOLLOWING STANDARD.

11.1.1. THE METHOD OF PRESERVING GOODS

AFTER DELIVERY OF GOODS FROM AMSON TO PURCHASER. PURCHASER SHALL CONTROL THE LCM AT -10℃ TO 40℃ ,AND IT MIGHT BE DESIRABLE TO KEEP AT THE NORMAL ROOM TEMPERATURE AND HUMIDITY UNTIL INCOMING INSPECTION OR THROWING INTO PROCESS LINE.

11.1.2. INCOMING INSPECTION

(A) THE METHOD OF INSPECTION

IF PURCHASER MAKE AN INCOMING INSPECTION , A SAMPLING PLAN SHALL BE APPLIED ON THE CONDITION THAT QUALITY OF ONE DELIVERY SHALL BE REGARDED AS ONE LOT.

(B) THE STANDARD OF QUALITY

ISO-2859-1 (SAME AS MIL-STD-105E) , LEVEL II SINGLE PLAN.

CLASS	AQL(%)
CRITICAL	0.4 %
MAJOR	0.65 %
MINOR	1.5 %
TOTAL	1.5 %

EVERY ITEM SHALL BE INSPECTED ACCORDING TO THE CLASS.

(C) MEASURE

IF AS THE RESULT OF ABOVE RECEIVING INSPECTION , A LOT OUT IS DISCOVERED. PURCHASER SHALL BE INFORM SELLER OF IT WITHIN SEVEN DAYS. BUT FIRST SHIPMENT WITHIN FOURTEEN DAYS.

11.1.3. WARRANTY POLICY

AMSON WILL PROVIDE ONE-YEAR WARRANTY FOR THE PRODUCTS ONLY IF UNDER SPECIFICATION OPERATING CONDITIONS. AMSON WILL REPLACE NEW PRODUCTS FOR THESE DEFECT PRODUCTS WHICH UNDER WARRANTY PERIOD AND BELONG TO THE RESPONSIBILITY OF AMSON.

11.2. CHECKING CONDITION

11.2.1.CHECKING DIRECTION SHALL BE IN THE 45 DEGREE AREA TO FACE THE SAMPLE.

11.2.2.CHECKER SHALL SEE OVER 300±25 mm. WITH BARE EYES FAR FROM SAMPLE AND USING 2 PCS. OF 20W FLUORESCENT LAMP.



11.3. INSPECTION PLAN :

CLASS	ITEM	JUDGEMENT	CLASS
PACKING & INDICATE	1. OUTSIDE AND INSIDE PACKAGE	"MODEL NO." , "LOT NO." AND "QUANTITY" SHOULD INDICATE ON THE PACKAGE.	Minor
	2. MODEL MIXED AND QUANTITY	OTHER MODEL MIXED.....REJECTED QUANTITY SHORT OR OVER.....REJECTED	Critical
	3. PRODUCT INDICATION	"MODEL NO." SHOULD INDICATE ON THE PRODUCT	Major
ASSEMBLY	4. DIMENSION, LCD GLASS SCRATCH AND SCRIBE DEFECT.	ACCORDING TO SPECIFICATION OR DRAWING.	Major
APPEARANCE	5. VIEWING AREA	POLARIZER EDGE OR LCD'S SEALING LINE IS VISABLE IN THE VIEWING AREAREJECTED	Minor
	6. BLEMISH · BLACK SPOT · WHITE SPOT IN THE LCD AND LCD GLASS CRACKS	ACCORDING TO STANDARD OF VISUAL INSPECTION(INSIDE VIEWING AREA)	Minor
	7. BLEMISH · BLACK SPOT WHITE SPOT AND SCRATCH ON THE POLARIZER	ACCORDING TO STANDARD OF VISUAL INSPECTION(INSIDE VIEWING AREA)	Minor
	8. BUBBLE IN POLARIZER	ACCORDING TO STANDARD OF VISUAL INSPECTION(INSIDE VIEWING AREA)	Minor
	9. LCD'S RAINBOW COLOR	STRONG DEVIATION COLOR (OR NEWTON RING) OF LCD.....REJECTED. OR ACCORDING TO LIMITED SAMPLE (IF NEEDED, AND INSIDE VIEWING AREA)	Minor
ELECTRICAL	10. ELECTRICAL AND OPTICAL CHARACTERISTICS (CONTRAST· VOP · CHROMATICITY ... ETC)	ACCORDING TO SPECIFICATION OR DRAWING . (INSIDE VIEWING AREA)	Critical
	11.MISSING LINE	MISSING DOT · LINE · CHARACTERREJECTED	Critical
	12.SHORT CIRCUIT· WRONG PATTERN DISPLAY	NO DISPLAY · WRONG PATTERN DISPLAY · CURRENT CONSUMPTION OUT OF SPECIFICATION..... REJECTED	Critical
	13. DOT DEFECT (FOR COLOR AND TFT)	ACCORDING TO STANDARD OF VISUAL INSPECTION	Minor



NO.	CLASS	ITEM	JUDGEMENT																				
11.4.1	MINOR	BLACK AND WHITE SPOT FOREIGN MATERIEL DUST IN THE CELL BLEMISH SCRATCH	<p>(A) ROUND TYPE: unit : mm.</p> <table border="1"> <thead> <tr> <th>DIAMETER (mm.)</th> <th>ACCEPTABLE Q'TY</th> </tr> </thead> <tbody> <tr> <td>$\Phi \leq 0.15$</td> <td>Distance>1mm</td> </tr> <tr> <td>$0.15 < \Phi \leq 0.4$</td> <td>3 (Distance>15mm)</td> </tr> <tr> <td>$0.4 < \Phi$</td> <td>0</td> </tr> </tbody> </table> <p>NOTE: $\Phi=(\text{LENGTH}+\text{WIDTH})/2$</p> <p>(B) LINEAR TYPE: unit : mm.</p> <table border="1"> <thead> <tr> <th>LENGTH</th> <th>WIDTH</th> <th>ACCEPTABLE Q'TY</th> </tr> </thead> <tbody> <tr> <td>-----</td> <td>$W \leq 0.03$</td> <td>Distance>1mm</td> </tr> <tr> <td>$L \leq 4.0$</td> <td>$0.03 < W \leq 0.05$</td> <td>3 (Distance>15mm)</td> </tr> <tr> <td>-----</td> <td>$0.05 < W$</td> <td>FOLLOW ROUND TYPE</td> </tr> </tbody> </table>	DIAMETER (mm.)	ACCEPTABLE Q'TY	$\Phi \leq 0.15$	Distance>1mm	$0.15 < \Phi \leq 0.4$	3 (Distance>15mm)	$0.4 < \Phi$	0	LENGTH	WIDTH	ACCEPTABLE Q'TY	-----	$W \leq 0.03$	Distance>1mm	$L \leq 4.0$	$0.03 < W \leq 0.05$	3 (Distance>15mm)	-----	$0.05 < W$	FOLLOW ROUND TYPE
DIAMETER (mm.)	ACCEPTABLE Q'TY																						
$\Phi \leq 0.15$	Distance>1mm																						
$0.15 < \Phi \leq 0.4$	3 (Distance>15mm)																						
$0.4 < \Phi$	0																						
LENGTH	WIDTH	ACCEPTABLE Q'TY																					
-----	$W \leq 0.03$	Distance>1mm																					
$L \leq 4.0$	$0.03 < W \leq 0.05$	3 (Distance>15mm)																					
-----	$0.05 < W$	FOLLOW ROUND TYPE																					
11.4.2	MINOR	BUBBLE IN POLARIZER DENT ON POLARIZER	<p style="text-align:right">unit : mm.</p> <table border="1"> <thead> <tr> <th>DIAMETER</th> <th>ACCEPTABLE Q'TY</th> </tr> </thead> <tbody> <tr> <td>$\Phi \leq 0.2$</td> <td>Distance>1mm</td> </tr> <tr> <td>$0.2 < \Phi \leq 0.5$</td> <td>3 (Distance>15mm)</td> </tr> <tr> <td>$0.5 < \Phi$</td> <td>0</td> </tr> </tbody> </table>	DIAMETER	ACCEPTABLE Q'TY	$\Phi \leq 0.2$	Distance>1mm	$0.2 < \Phi \leq 0.5$	3 (Distance>15mm)	$0.5 < \Phi$	0												
DIAMETER	ACCEPTABLE Q'TY																						
$\Phi \leq 0.2$	Distance>1mm																						
$0.2 < \Phi \leq 0.5$	3 (Distance>15mm)																						
$0.5 < \Phi$	0																						
11.4.3	MINOR	Dot Defect	<table border="1"> <thead> <tr> <th>Items</th> <th>ACC. Q'TY</th> </tr> </thead> <tbody> <tr> <td>Bright dot</td> <td>$N \leq 2$ (Distance≥ 15mm)</td> </tr> <tr> <td>Dark dot</td> <td>$N \leq 3$ (Distance≥ 15mm)</td> </tr> </tbody> </table> <p>Pixel Define :</p> <p>Note 1: The definition of dot: The size of a defective dot over 1/2 of whole dot is regarded as one defective dot. Definitition:<1/2dot and visible by 6% ND filter $N \leq 5$</p> <p>Note 2: Bright dot: Dots appear bright and unchanged in size in which LCD panel is displaying under black pattern.</p> <p>Note 3: Dark dot: Dots appear dark and unchanged in size in which LCD panel is displaying under pure red, green ,blue pattern.</p>	Items	ACC. Q'TY	Bright dot	$N \leq 2$ (Distance ≥ 15 mm)	Dark dot	$N \leq 3$ (Distance ≥ 15 mm)														
Items	ACC. Q'TY																						
Bright dot	$N \leq 2$ (Distance ≥ 15 mm)																						
Dark dot	$N \leq 3$ (Distance ≥ 15 mm)																						
11.4.4	MINOR	Mura	Not visible through 6% ND filter in 50% gray or judge by limit sample if necessary																				

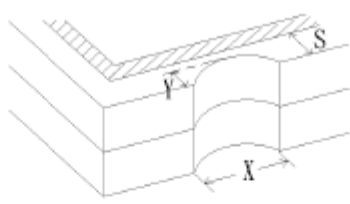
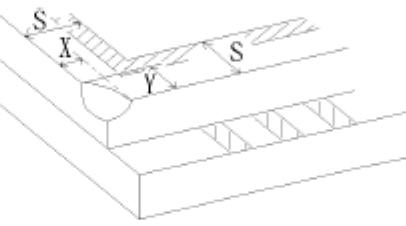
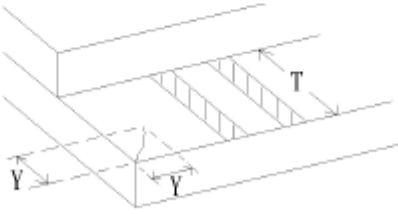
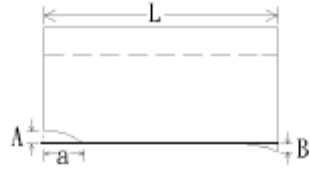
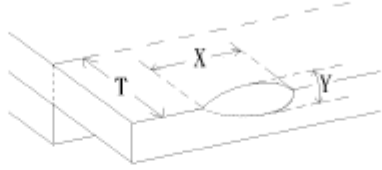
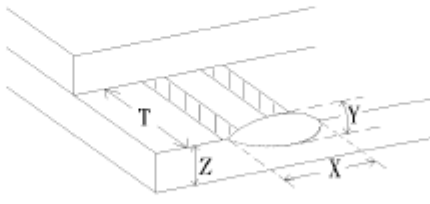
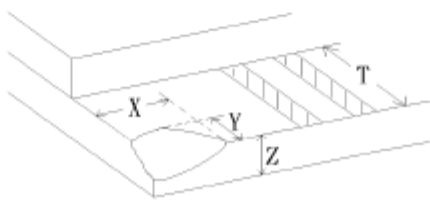

NO.	CLASS	ITEM	JUDGEMENT
11.4.4	MINOR	LCD GLASS CHIPPING	 $Y > S$ Reject
11.4.5	MINOR	LCD GLASS CHIPPING	 $X \text{ or } Y > S$ Reject
11.4.6	MAJOR	LCD GLASS GLASS CRACK	 $Y > (1/2) T$ Reject
11.4.7	MAJOR	LCD GLASS SCRIBE DEFECT	 <ol style="list-style-type: none"> $a > L/3$, $A > 1.5\text{mm}$. Reject B: ACCORDING TO DIMENSION
11.4.8	MINOR	LCD GLASS CHIPPING (ON THE TERMINAL AREA)	 $\Phi = (x+y)/2 > 2.5 \text{ mm}$ Reject
11.4.9	MINOR	LCD GLASS CHIPPING (ON THE TERMINAL SURFACE)	 $Y > (1/3) T$ Reject
11.4.10	MINOR	LCD GLASS CHIPPING	 $Y > T$ Reject



12. Handling Precautions

12.1 Mounting method

The LCD panel of Kingtech TFT module consists of two thin glass plates with polarizers which easily be damaged. And since the module is so constructed as to be fixed by utilizing fitting holes in the printed circuit board.

Extreme care should be needed when handling the LCD modules.

12.2 Caution of LCD handling and cleaning

When cleaning the display surface, Use soft cloth with solvent

[Recommended below] and wipe lightly

- Isopropyl alcohol
- Ethyl alcohol

Do not wipe the display surface with dry or hard materials that will damage the polarizer surface.

Do not use the following solvent:

- Water
- Aromatics

Do not wipe ITO pad area with the dry or hard materials that will damage the ITO patterns

Do not use the following solvent on the pad or prevent it from being contaminated:

- Soldering flux
- Chlorine (Cl) , Sulfur (S)

If goods were sent without being silicon coated on the pad, ITO patterns could be damaged due to the corrosion as time goes on.

If ITO corrosion happens by miss-handling or using some materials such as Chlorine (Cl), Sulfur (S) from customer, Responsibility is on customer.

12.3 Caution against static charge

The LCD module uses C-MOS LSI drivers, so we recommend that you:

Connect any unused input terminal to POWER or GROUND, do not input any signals before power is turned on, and ground your body, work/assembly areas, and assembly equipment to protect against static electricity.

12.4 packing

- Module employs LCD elements and must be treated as such.
- Avoid intense shock and falls from a height.
- To prevent modules from degradation, do not operate or store them exposed direct to sunshine or high temperature/humidity

12.5 Caution for operation

- It is an indispensable condition to drive LCD's within the specified voltage limit since the higher voltage than the limit causes the shorter LCD life.
- An electrochemical reaction due to direct current causes LCD's undesirable deterioration, so that the use of direct current drive should be avoided.
- Response time will be extremely delayed at lower temperature than the operating temperature range and on the other hand at higher temperature LCD's show dark color in them. However those phenomena do not mean malfunction or out of order with LCD's, which will come back in the specified operation temperature.
- If the display area is pushed hard during operation, some font will be abnormally displayed but it resumes normal condition after turning off once.
- Slight dew depositing on terminals is a cause for electro-chemical reaction resulting in terminal open circuit.

Usage under the maximum operating temperature, 50%Rh or less is required.



12.6 storing

In the case of storing for a long period of time for instance, for years for the purpose or replacement use, the following ways are recommended.

- Storage in a polyethylene bag with the opening sealed so as not to enter fresh air outside in it. And with no desiccant.
- Placing in a dark place where neither exposure to direct sunlight nor light's keeping the storage temperature range.
- Storing with no touch on polarizer surface by the anything else.
[It is recommended to store them as they have been contained in the inner container at the time of delivery from us

12.7 Safety

- It is recommendable to crash damaged or unnecessary LCD's into pieces and wash off liquid crystal by either of solvents such as acetone and ethanol, which should be burned up later.
- When any liquid leaked out of a damaged glass cell comes in contact with your hands, please wash it off well with soap and water

13. Precaution for Use

13.1

A limit sample should be provided by the both parties on an occasion when the both parties agreed its necessity. Judgment by a limit sample shall take effect after the limit sample has been established and confirmed by the both parties.

13.2

On the following occasions, the handing of problem should be decided through discussion and agreement between responsible of the both parties.

- When a question is arisen in this specification
- When a new problem is arisen which is not specified in this specifications
- When an inspection specifications change or operating condition change in customer is reported to Kingtech TFT , and some problem is arisen in this specification due to the change
- When a new problem is arisen at the customer's operating set for sample evaluation in the customer site.



14. Packing Method

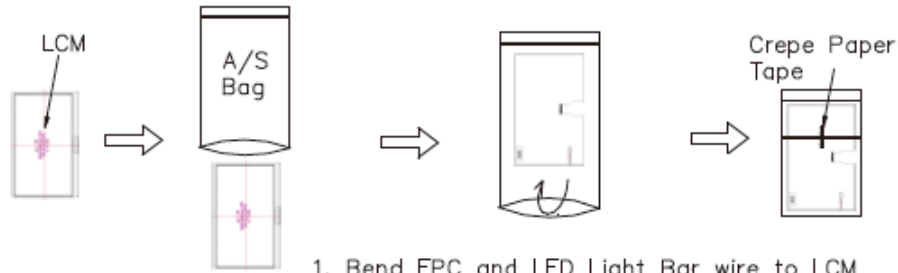

1. Bend FPC and LED Light Bar wire to LCM backside.
2. Fix with crepe paper tape .
3. Put LCM into A/S BAG .

Partition + Corrugated Bar*2

Corrugated paper

DUST-PROOF-BAG

Corrugated Bar*2

