



PRODUCT SPECIFICATIONS

For Customer: _____

: APPROVAL FOR SPECIFICATION

Customer Model No. _____

: APPROVAL FOR SAMPLE

Module No.: PV104010D0160L

Date : 2023-1-7

Table of Contents

No.	Item	Page
1	Cover Sheet(Table of Contents)	
2	Revision Record	
3	General Specifications	
4	Outline Drawing	
5	Absolute Maximum Ratings	
6	Electrical Specifications	
7	Optical Characteristics	
8	Reliability Test Items and Criteria	
9	Precautions for Use of LCD Modules	

For Customer's Acceptance:

Approved By	Comment

PREPARED	CHECKED	VERIFIED BY QA DEPT	VERIFIED BY R&D DEPT
RCR			



2. Revision Record

Date	Rev.No.	Page	Revision Items	Prepared
2023.1.7	V0		The first release	RCR



3. General Specifications

PV104010D0160L is a TFT-LCD module. It is composed of a TFT-LCD panel, driver IC, FPC, a back light unit. The 10.4" display area contains 800 x (RGB) x 600 pixels and can display up to 16.7M colors. This product accords with ROHS environmental criterion.

3.1 TFT General Specifications

Item	Contents	Unit	Note
LCD Type	TFT	-	
Display color	16.7M	Color	
Viewing Direction(Gray inversion angle)	6 O'clock	O'Clock	
Display mode	TN Normally white		
Display Orientation	Landscape Only		
Module size	228.5 X 175.5 X 5.9	mm	
Active Area(W×H)	211.2 X158.4	mm	
Number of Dots	800(RGB) X 600	dots	
Backlight	3S14P-LEDs (white)	pcs	
Interface	RGB-24bits	-	



4.Outline.Drawing

Mechanical Drawing Drawing Attachment: Front

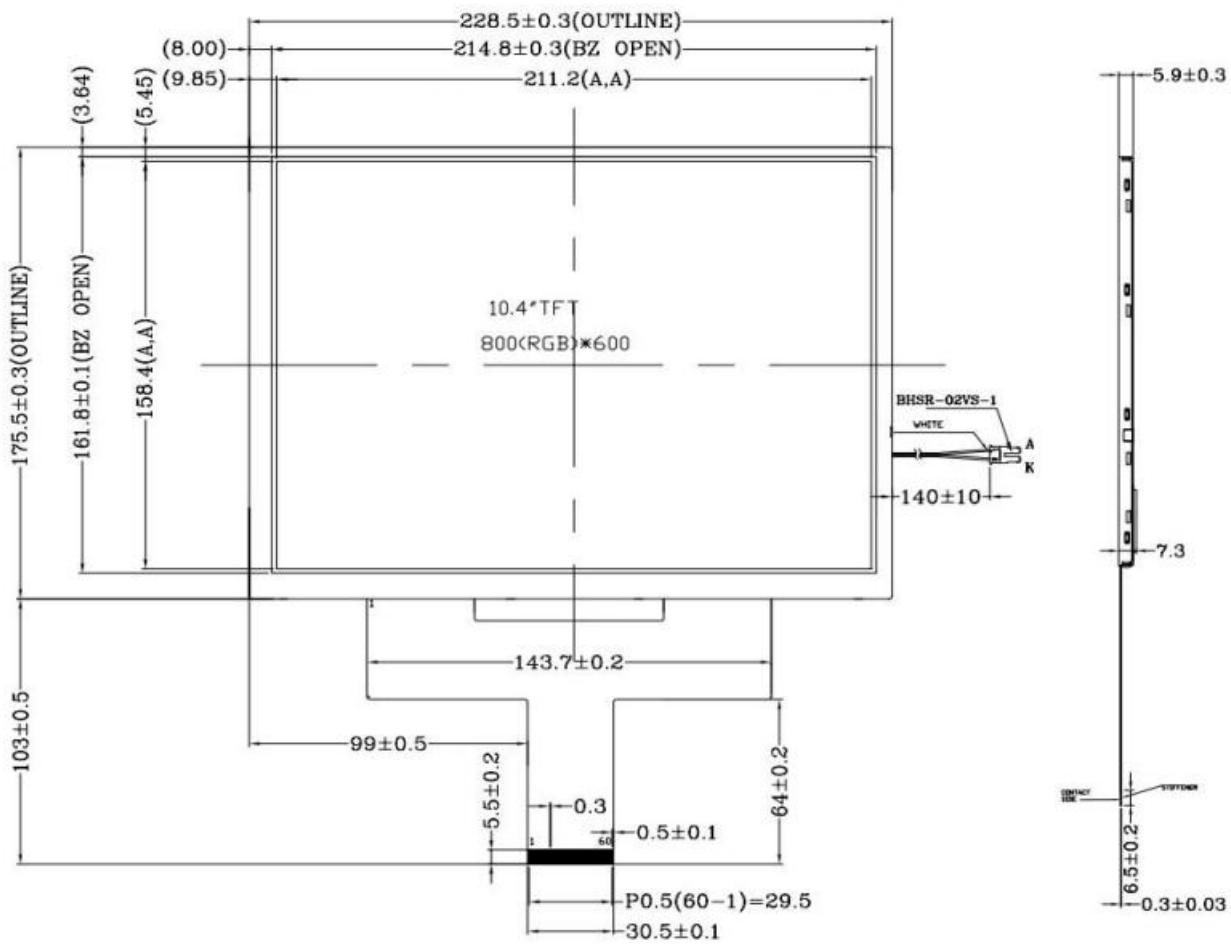



Mechanical Drawing Drawing Attachment: Back

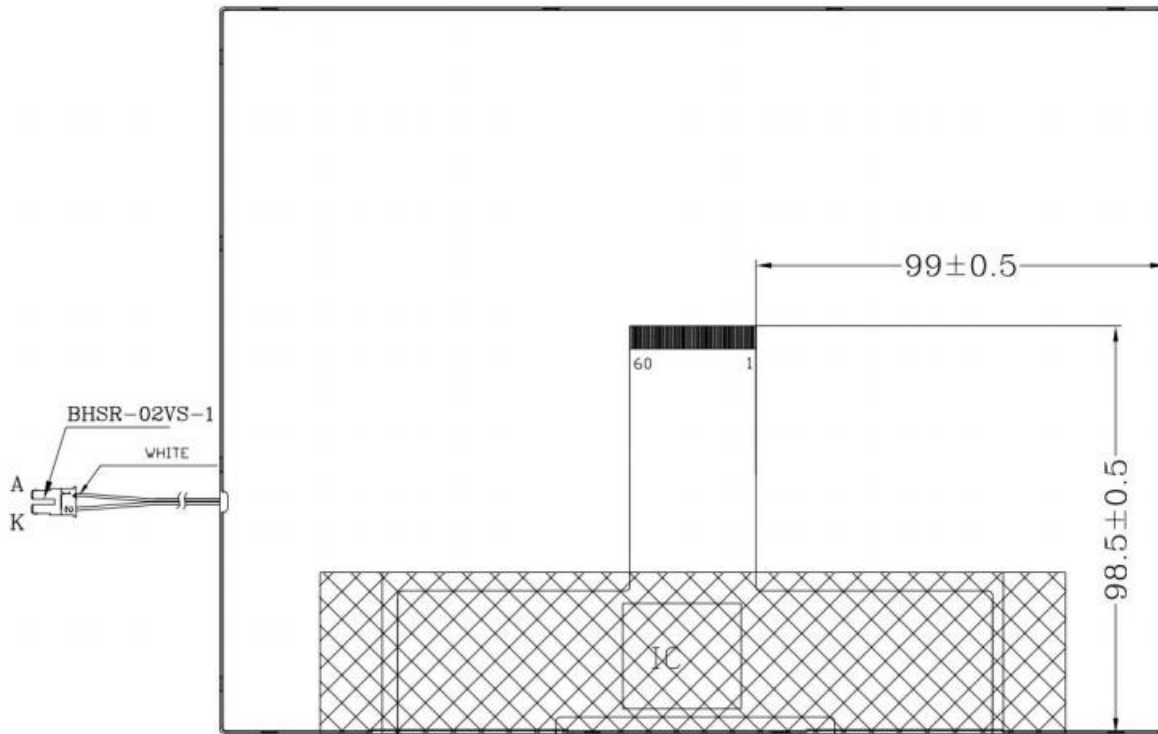



5. Absolute Maximum Ratings(Ta=25 °C)

5.1 Electrical Absolute Maximum Ratings.(Vss=0V ,Ta=25 °C)

Parameter		Symbol	Min.	Max.	Unit	Remarks
Power Supply	LCD Module	VCC	VSS-0.3	3.9	V	Ta = 25 °C
		VLED	VSS-0.3	9.9	V	
	BLU	ILED	-	360	mA	
Operating Temperature		T _{OP}	-20	+70	°C	Note 1
Storage Temperature		T _{ST}	-20	+70	°C	

Note : 1) Temperature and relative humidity range are shown in the figure below.
Wet bulb temperature should be 39 °C max. and no condensation of water.

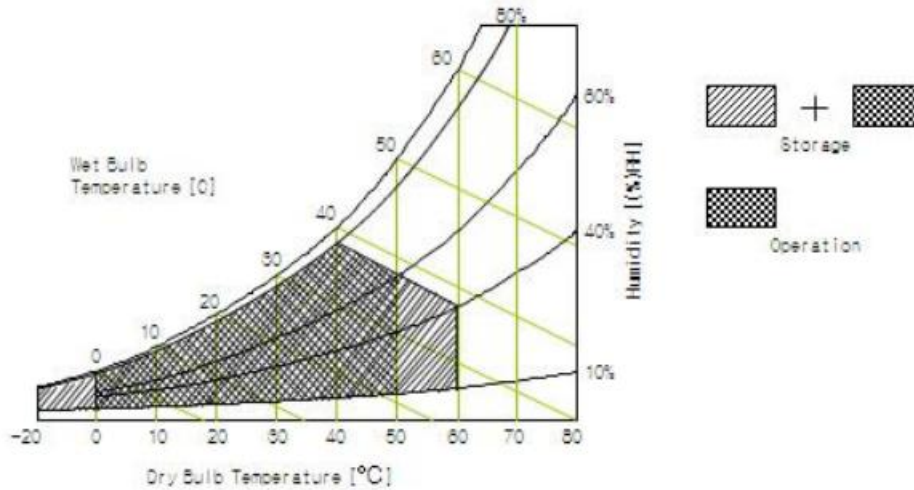



6. Electrical Specifications

6.1 Electrical characteristics(V_{CC}=0V, T_{op}=25°C)

Parameter	Symbol	Values			Unit	Notes
		Min.	Typ.	Max.		
Power Supply Voltage	VCC	3.0	3.3	3.6	V	
Power Supply Current	IDD	--	150	--	mA	
Power Consumption	PLCD	--	0.495	--	W	
Power Supply Voltage	AVDD	8.5	9	10.5	V	
	VGH	17	18	19	V	
	VGL	-9	-8	-7	V	
	VCOM	3.5	3.92	4.2	V	
Current Consumption	I _{VCC}		153		mA	
	I _{AVDD}		30	40	mA	
	I _{VGH}		0.2		mA	
	I _{VGL}		0.78		mA	
	I _{VCOM}		33		uA	

Notes : 1. The supply voltage is measured and specified at the interface connector of LCM.
 The current draw and power consumption specified is for V_{BAT}=3.8V, Frame rate f_v=60Hz and Clock frequency = 156.8MHz. Test Pattern of power supply current

a) Typ : Mosaic 8 x 6 Pattern(L0/L255)

b) Max : Black

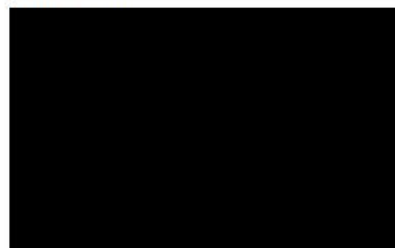
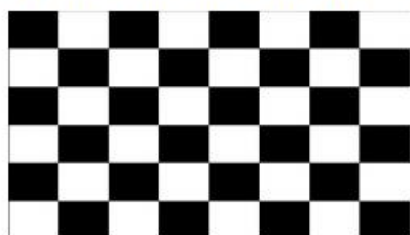

2. The duration of rush current is about 2ms and rising time of Power Input is 1ms(min)



6.2 LED backlight specification(VSS=0V ,Ta=25°C)

Parameter	Symbol	Values			Unit	Notes
		Min.	Typ.	Max.		
LED Supply Voltage	VLED	8.4	8.7	9.6	V	
	VRP	--	350	420	mV	Ripple
LED Forward Current	ILED	--	--	25	mA	Note 1
Power Consumption	PLED	--	3.1	--	W	
LED Quantity	QLED	--	36	--	EA	
LED Life Time	TLED	30000	--	--	Hrs	Note 2

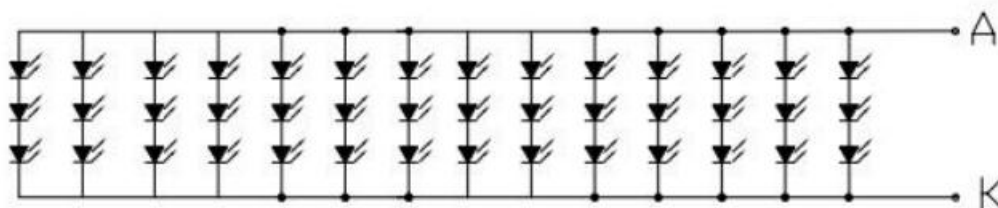

Notes: 1. $I_{LED} = 14 \times 25\text{mA} = 350\text{mA}$, 14Parallel*3String

$PLED = V_{LED} \times I_{LED}$ (Without LED converter transfer efficiency)

2. The life time of LED, 30,000Hrs, is determined as the time at which luminance of the LED is 50% compared to that of initial value at the typical LED current on condition of continuous operating at $25 \pm 2^\circ\text{C}$.



6.3 INPUT TERMINAL PIN ASSIGNMENT

This LCD employs two interface connections, a 60 pin FFC connector is used for the LCD module electronics interface and a 2 pin JOIN TEK connector is used for the internal backlight system.

3.3.1 Pin assignment for LCD module

Connector : HRS FH28-60S-0.5SH or equivalent

Pin No.	Symbol	Description
1	GND	Ground
2	AVDD	Power for Analog Circuit
3	VCC	Power Supply
4-11	R0-R7	Red data Input
12-19	G0-G7	Green data Input
20-27	B0-B7	Blue data Input
28	DCLK	Clock input(Latch data at falling edge)
29	DE	Data enable
30	HSYNC	Horizontal sync input. Negative polarity
31	VSNC	Vertical sync input. Negative polarity
32	MODE	DE/SYNC mode select .normally pull high H:DE mode .L:HV sync mode
33-35	NC	No connection
36	VCC	Power Supply
37	NC	No connection
38-39	GND	Ground
40	AVDD	Power for Analog Circuit
41	VCOM	Common Voltage
42	DITH	H:Disable dithering function L:Enable dithering function
43-55	NC	No connection
56	VGH	Gate No Voltage
57	VCC	Power supply
58	VGL	Gate Off Voltage
59	GND	Ground
60	NC	No connection (please leave it open)



Backlight Pin Assignment

Connector : BHSR-02VS-1 or equivalent

Pin No	Symbol	Description	Remarks
1	VLED+	Backlighting LED anode	
2	VLED-	Backlighting LED cathode	

6.4 TFT-LCD Power Us Sequence

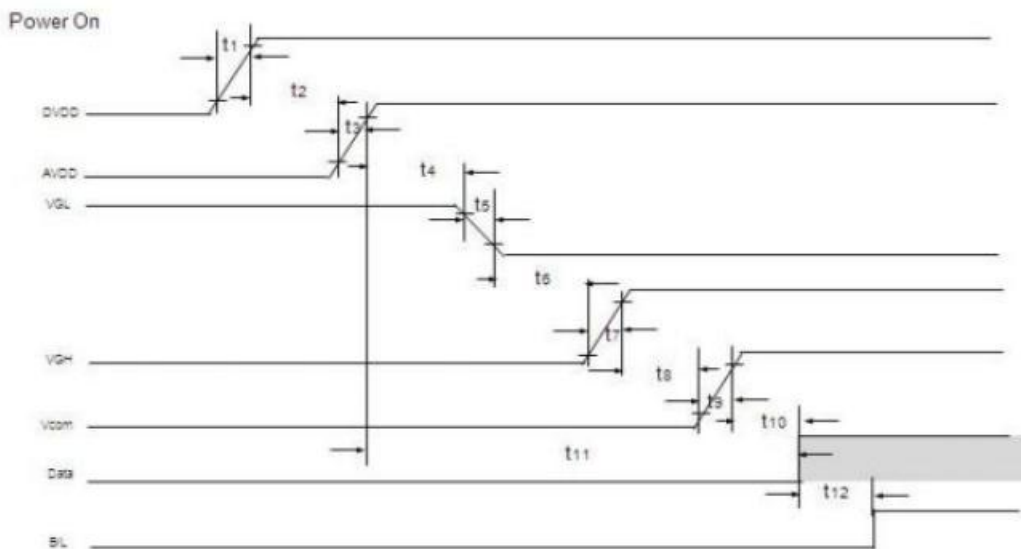

Symbol	Value			Unit	Note
	Min.	Typ.	Max.		
t1	0.1	-	20	ms	
t2	16	-	-	ms	
t3	0.1	-	10	ms	
t4	5	-	-	ms	
t5	0.1	-	10	ms	
t6	5	-	-	ms	
t7	0.1	-	10	ms	
t8	5	-	-	ms	
t9	0.1	-	10	ms	
t10	20	-	-	ms	
t11	38	-	80	ms	
t12	200	-	-	ms	



6.5 RGB Input Timing Table

Horizontal Timing

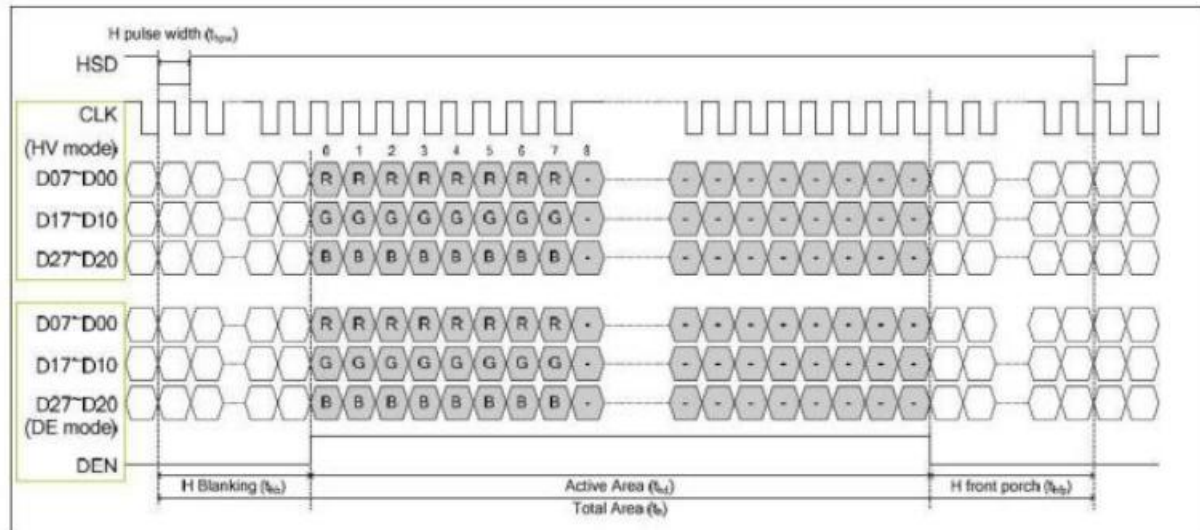

Vertical Timing

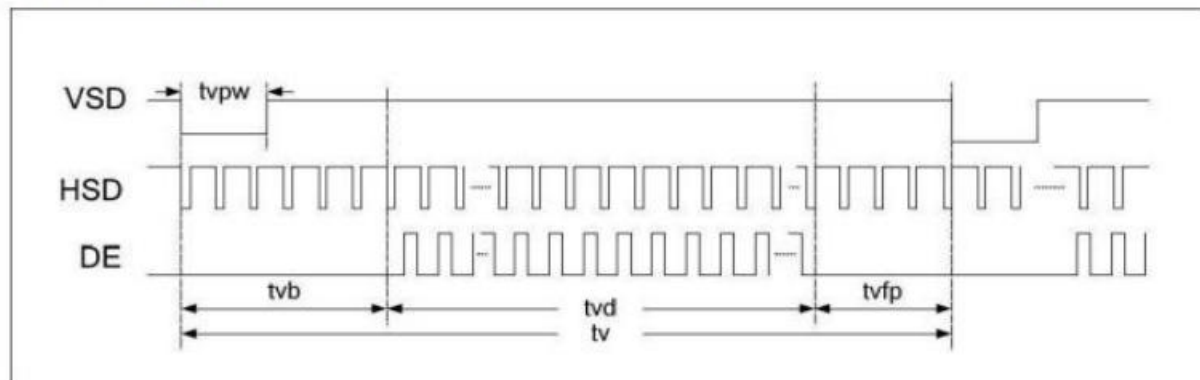



6.6 Interface timing Parameter

Item		Symbol	min	typ	max	UNIT	
LCD	Frame Rate	-	-	60	-	Hz	
	Pixels Rate	-	33	40	50	MHz	
Timing	Horizontal	Horizontal total time	tHP	-	1056	-	t _{CLK}
		Horizontal Active time	tHadr	800			t _{CLK}
		Horizontal Back Porch	tHBP		48		t _{CLK}
		Horizontal Front Porch	tHFP	16	210	354	t _{CLK}
	Vertical	Vertical total time	tvp	624	635	700	t _H
		Vertical Active time	tVadr	600			t _H
		Vertical Back Porch	tVBP		23		t _H
		Vertical Front Porch	tVFP	1	12	77	t _H
Lane			-	1	-	Lane	

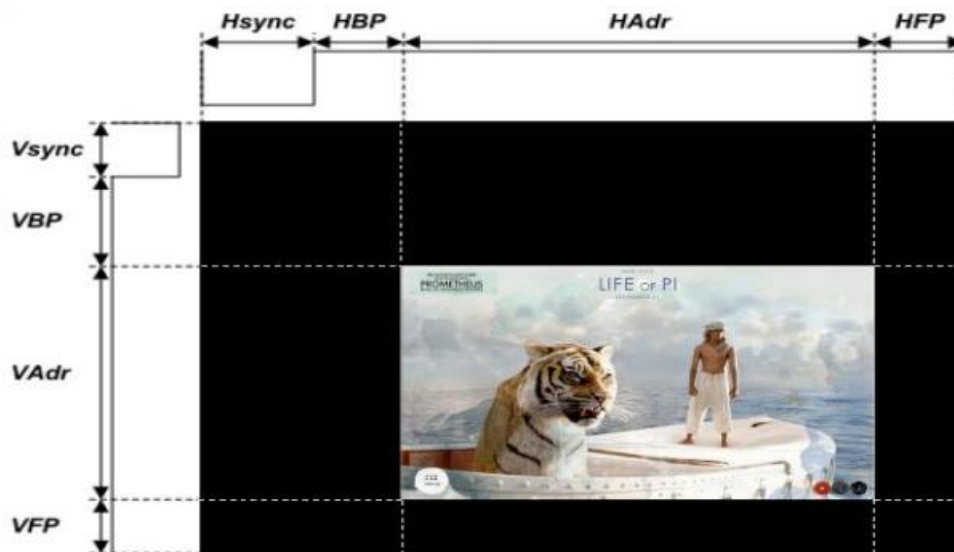



7. Optical Characteristics

Item	Symbol	Condition	Min.	Typ.	Max.	Unit	Note	
Brightness	Bp	$\theta=0^\circ$	300	350	-	Cd/m ²	1	
Uniformity	Δ Bp	$\Phi=0^\circ$	70	80	-	%	1,2	
Viewing Angle	3:00	$Cr \geq 10$	-	80	-	Deg	3	
	6:00		-	60	-			
	9:00		-	80	-			
	12:00		-	45	-			
Contrast Ratio	Cr	$\theta=0^\circ$	-	600	-	-	4	
Response Time	T_r+T_f	$\Phi=0^\circ$	-	30	35	ms	5	
Color of CIE Coordinate	W	x	$\theta=0^\circ$ $\Phi=0^\circ$	Typ. -0.05	0.284	Typ. +0.05	-	1,6
		y			0.320		-	
	R	x			0.604		-	
		y			0.326		-	
	G	x			0.309		-	
		y			0.578		-	
	B	x			0.149		-	
		y			0.100		-	
NTSC	S		50	55	-	%		

Note: The parameter is slightly changed by temperature, driving voltage and material



Note 1: The data are measured after LEDs are turned on for 5 minutes. LCM displays full white. The brightness is the average value of 9 measured spots. Measurement equipment BM-7 (Φ5mm)

Measuring condition:

- *Measuring surroundings: Dark room.*
- *Measuring temperature: Ta=25 °C.*
- *Adjust operating voltage to get optimum contrast at the center of the display.*

Measured value at the center point of LCD panel after more than 5 minutes while backlight turning on.

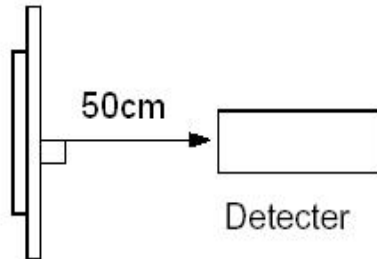

Note 2: The luminance uniformity is calculated by using following formula.

$$\Delta Bp = Bp (\text{Min.}) / Bp (\text{Max.}) \times 100 (\%)$$

Bp (Max.) = Maximum brightness in 9 measured spots

Bp (Min.) = Minimum brightness in 9 measured spots.

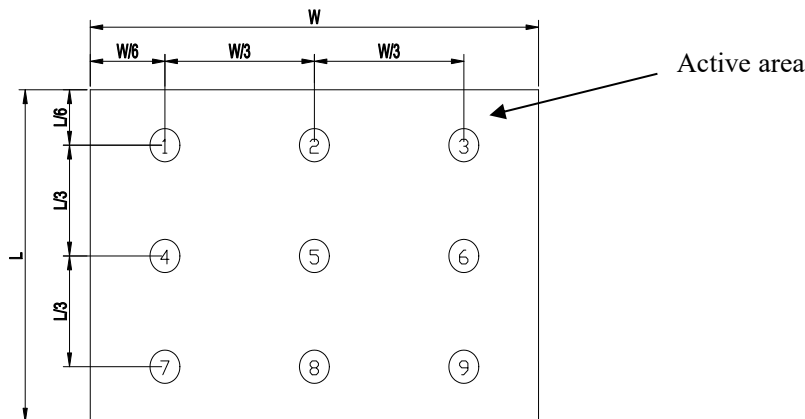



Note 3: The definition of viewing angle:
Refer to the graph below marked by θ and Φ

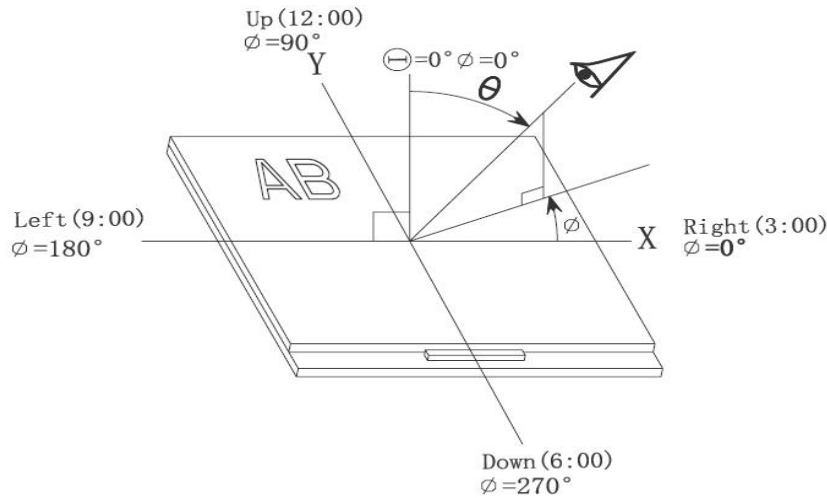

Note 4: Definition of contrast ratio.(Test LCD using DMS501)

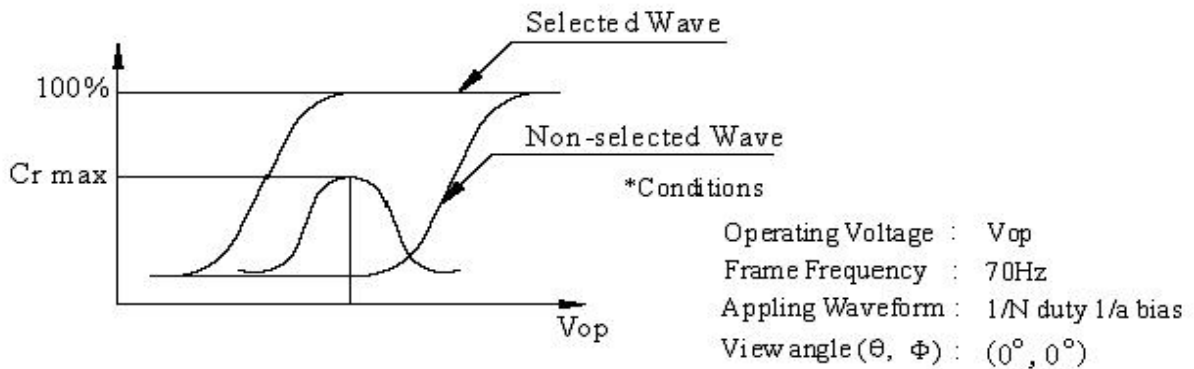

$$\text{Contrast ratio}(Cr) = \frac{\text{Brightness of selected dots}}{\text{Brightness of non-selected dots}}$$

Note 5: Definition of Response time. (Test LCD using DMS501):

The output signals of photo detector are measured when the input signals are changed from "black" to "white" (falling time) and from "white" to "black" (rising time), respectively. The response time is defined as the time interval between the 10% and 90% of amplitudes. Refer to figure as below.

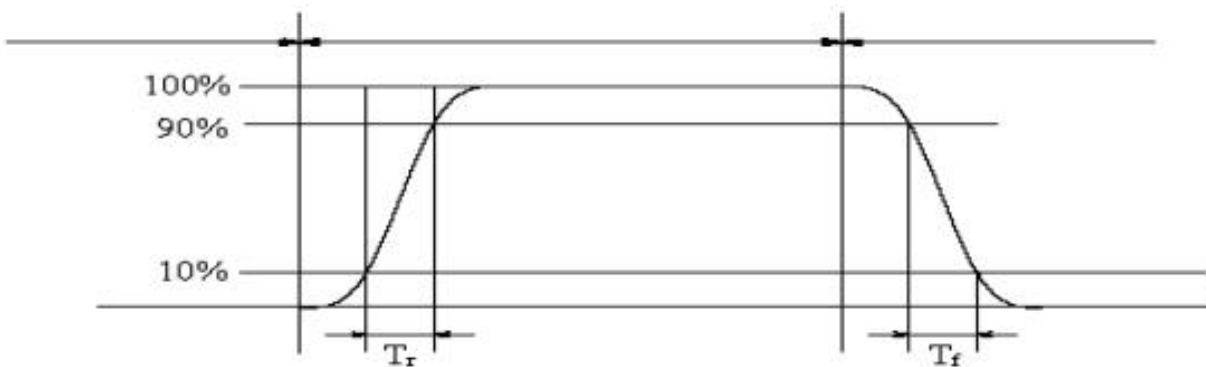

The definition of response time



Note 6: Definition of Color of CIE Coordinate and NTSC Ratio.

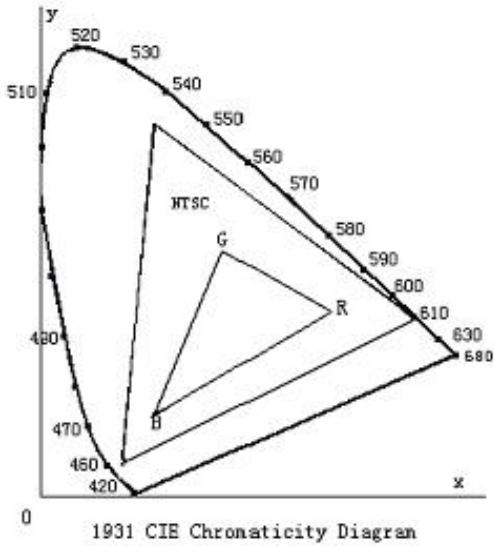

Color gamut:

$$S = \frac{\text{area of RGB triangle}}{\text{area of NTSC triangle}} \times 100\%$$

Note 7: Definition of cross talk.

Cross talk ratio(%)=|pattern A Brightness-pattern B Brightness|/pattern A Brightness*100

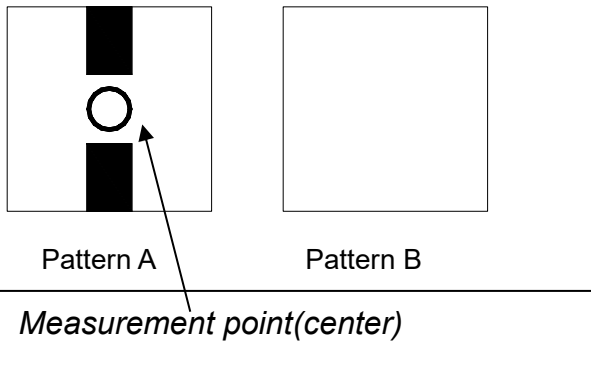

Electric volume value=3F+/-3Hex



8. Reliability Test Items and Criteria

Test Item	Test condition	Remark
High Temperature Storage	Ta = 70°C 120hrs	Note1,Note3, 4
Low Temperature Storage	Ta = -20°C 120hrs	Note1,Note3, 4
High Temperature Operation	Ta = 70°C 120hrs	Note2,Note3, 4
Low Temperature Operation	Ta = -20°C 120hrs	Note1,Note3, 4
Operation at High Temperature/Humidity	+40°C, 90%RH 120hrs	Note3, 4
Thermal Shock	-20°C/30 min ~ +70°C/30 min for a total 10 cycles, Start with cold temperature and end with high temperature.	Note3, 4
Package Vibration Test	Random Vibration : 0.015G*G/Hz from 5-200HZ, -6dB/Octave from 200-500HZ 2 hours for each direction of X. Y. Z. (6 hours for total)	
Package Drop Test	Height:60cm 1 corner, 3 edges, 6 surfaces	
Electro Static Discharge	150pF, 330 Ω , ±6kV(Contact), ±8kV (Air)	

Note 1: Ta is the ambient temperature of samples.

Note 2: Ts is the temperature of panel's surface.

Note 3: In the standard condition, there shall be no practical problem that may affect the display function. After the reliability test, the product only guarantees operation, but don't guarantee all of the cosmetic specification.

Note 4: Before cosmetic and function test, the product must have enough recovery time,at least 2 hours at room temperature



9. Precautions for Use of LCD Modules

9.1 Handling Precautions

9.1.1 *The display panel is made of glass. Do not subject it to a mechanical shock by dropping it from a high place, etc.*

9.1.2 *If the display panel is damaged and the liquid crystal substance inside it leaks out, be sure not to get any in your mouth, if the substance comes into contact with your skin or clothes, promptly wash it off using soap and water.*

9.1.3 *Do not apply excessive force to the display surface or the adjoining areas since this may cause the color tone to vary.*

9.1.4 *The polarizer covering the display surface of the LCD module is soft and easily scratched. Handle this polarizer carefully.*

9.1.5 *If the display surface is contaminated, breathe on the surface and gently wipe it with a soft dry cloth. If still not completely clear, moisten cloth with one of the following solvents:*

— Isopropyl alcohol — Ethyl alcohol

Solvents other than those mentioned above may damage the polarizer. Especially, do not use the following:

— Water — Ketone — Aromatic solvents

9.1.6 *Do not attempt to disassemble the LCD Module.*

9.1.7 *If the logic circuit power is off, do not apply the input signals.*

9.1.8 *To prevent destruction of the elements by static electricity, be careful to maintain an optimum work environment.*

a. *Be sure to ground the body when handling the LCD Modules.*

b. *Tools required for assembly, such as soldering irons, must be properly ground.*

c. *To reduce the amount of static electricity generated, do not conduct assembly and other work under dry conditions.*

d. *The LCD Module is coated with a film to protect the display surface. Be care when peeling off this protective film since static electricity may be generated.*



9.2 Storage precautions

9.2.1 *When storing the LCD modules, avoid exposure to direct sunlight or to the light of fluorescent lamps.*

9.2.2 *The LCD modules should be stored under the storage temperature range. If the LCD modules will be stored for a long time, the recommend condition is:*

Temperature : 0 °C ~ 40 °C

Relatively humidity: ≤80%

9.2.3 *The LCD modules should be stored in the room without acid, alkali and harmful gas.*

9.3 *The LCD modules should be no falling and violent shocking during transportation, and also should avoid excessive press, water, damp and sunshine.*

END